



BRAND
HYDRAULICS Co.

Made in the Heartland of America
Serving the World

Engineering & Manufacturing Solutions

Joystick Control

EC20400

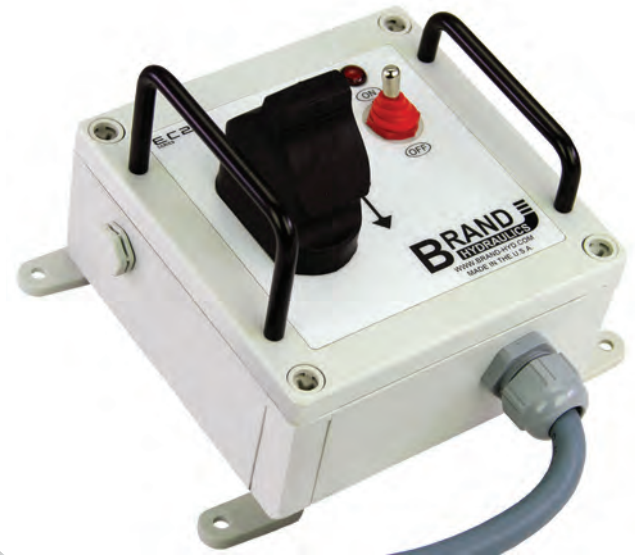

APPLICATION:

Proportionally control the speed and direction of hydraulic motors and cylinders. The EC20400 was designed primarily to be paired with a single section Brand Series 36 EFC, but other flow controls meeting the appropriate specifications may be used as well



ISO 9001:2008 WITH DESIGN
Certificate #02.002.1



402.344.4434 • www.brand-hyd.com



EC20400 Joystick Control

FEATURES:

- Pulse Width Modulated output proportional to joystick deflection.
- Plug and Play stack valve control, includes a switched output for each side of the levers center position.
- Precise control in a low profile ergonomic design.
- Weather tight control package.
- Protected against reverse polarity, short circuit, and over voltage conditions.
- Current controlled output, maintains output current regardless of supply voltage and coil resistance variations.
- On board proportional indicators for input signal and output signal. Also includes an on/off power and joystick status indicator.
- Two Enable lines are provided, one with adjustable soft stop, both with adjustable soft start.
- Independent ramp adjustments up and down, 0.1 - 12 seconds.
- Minimum and Maximum current adjustment for fine tuning the outputs span.
- Wide voltage supply range 12-30 VDC, one control for 12 or 24VDC systems.



DESCRIPTION:

The EC20400 is a compact weatherproof joystick control built with high quality long life components that are designed for use in harsh environments. The control comes loaded with user friendly features that provide versatility without sacrificing ease of use.

SPECIFICATIONS:

Voltage Supply	12-30 VDC
PWM Output Current	2.0 Amps Max Continuous
PWM Output Description	PWM , Pulse Width Modulation, 0-100% Duty cycle
PWM Output Frequency	107Hz +/- 5 Hertz
Switched DC Output Current	2.5 Amps Max Continuous Each Output (A and B)
Switched DC Output Voltage	Voltage Out = Voltage Supply - 0.7 Volts
Environmental Ratings	IP66 / NEMA 4
Operating Temperature	-40°C - 85°C (-40°F - 185°F)
Storage Temperature	-40°C - 85°C (-40°F - 185°F)

CONTROL LAYOUT:

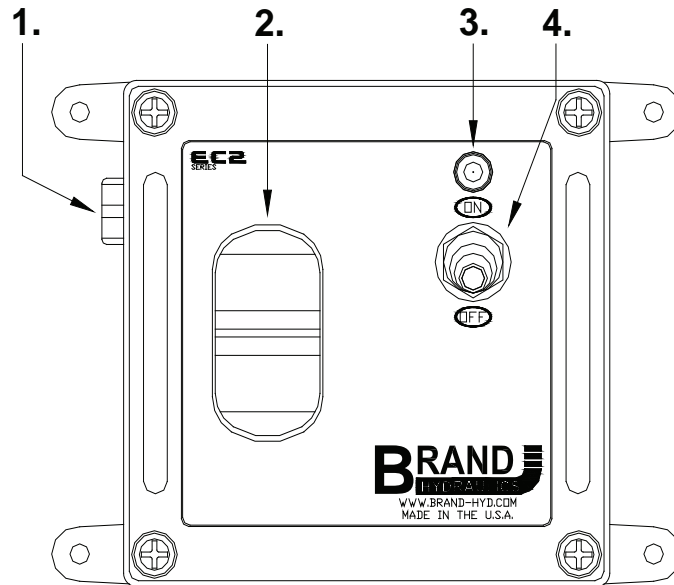
**Functions**

1. Waterproof altitude pressure and vapor release vent.
2. Single-axis, spring centered, fingertip joystick
3. Master power indicator.
4. Master power ON/OFF switch.

E1948 Output Cable

- Pin 1, Wire #1, Positive 12-30 VDC Supply Input
- Pin 2, Wire #2, Auxiliary battery output
- Pin 3, Wire #3, Ground
- Pin 4, Wire #4, Enable Input
- Pin 5, Wire #5, Ramping Enable Input
- Pin 6, Wire #6, "A" Coil Output
- Pin 7, Wire #7, Ground
- Pin 8, Wire #8, "B" Coil Output
- Pin 9, Wire #9, Ground
- Pin 10, Wire #10, Positive EFC Output
- Pin 11, Wire #11, Ground
- Pin 12, Wire Green/Yellow, System Ground

E1915 Mating Output Cable

- Pin 1, Red Wire, Positive 12-30 VDC Supply Input
- Pin 2, Yellow Wire, Auxiliary battery output
- Pin 3, Black, Ground
- Pin 4, Gray Wire, Enable Input
- Pin 5, White Wire, Ramping Enable Input
- Pin 6, Orange Wire, "A" Coil Output
- Pin 7, Black Wire, Ground
- Pin 8, Brown Wire, "B" Coil Output
- Pin 9, Black Wire, Ground
- Pin 10, Blue Wire, Positive EFC Output
- Pin 11, Black Wire, Ground
- Pin 12, Green Wire, System Ground

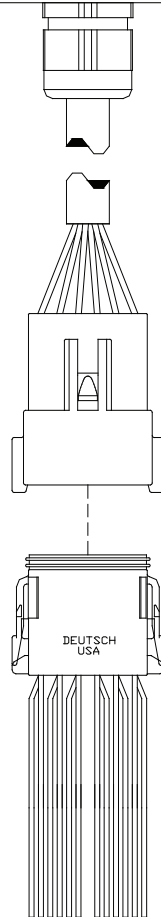
**Brand P/N: E1948**

Deutsch Connector P/Ns:
 Receptacle Body: DT04-12PB-E004
 Secondary Wedge: W12P
 Terminals, Male: 0460-202-16141

Brand P/N: E1915

Deutsch Connector P/Ns:
 Plug Body: DT06-12SB-P012
 Secondary Wedge: W12S-P012
 Terminals, Female: 0462-201-16141
 Wire: GXL Cross-Link, 16-AWG

EC20400 Joystick Control

INTERNAL LAYOUT:

Power LED

LED indicates when board has DC power present. LED turns off when the enable input becomes active (switched low).

Input Signal LED

Proportional to the level of input signal.

Output Signal LED

Proportional to the level of output current.

P.F.P. Potentiometer Fault Protection

A safety feature: P.F.P will shutdown the boards wiper input if the potentiometers ground becomes open or disconnected.

Terminal Block Wiring

T1

1. Positive 12-30 VDC Input
2. Auxiliary Supply Voltage output, Not to Exceed 2.5 Amp.
3. Positive output for EFC
4. Output A positive output
5. Output B positive output
6. System Ground input
7. Ground
8. Ground
9. Ground
10. Ground
11. Ground
12. Ground

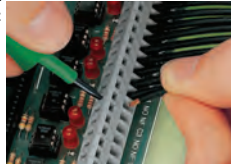

T2

1. Enable input, apply a ground to disable the board or leave open for normal operation.
2. Ramping Enable input, apply a ground to disable the board or leave open for normal operation.
3. Ground
4. Output A activation pin. Sending 6-30VDC to this pin will activate the A output (T1/pin4).
5. Output B activation pin. Sending 6-30VDC to this pin will activate the B output (T1/pin5).
6. Ground for Potentiometer. (Note: Wiper input will not function without the potentiometer being grounded at this pin.)
7. Potentiometer wiper Input, Not to Exceed 10V. Input Impedance is 10K Ohms.
8. 10V Reference for potentiometer.
9. Positive 0-10V signal input, Not to Exceed 10V. Input Impedance is 10K Ohms.
10. Positive 0-5V signal input, Not to Exceed 5V. Input Impedance is 10K Ohms.
11. Positive 4-20mA input. Current input only do not apply voltage to this pin. Input Impedance is 250 Ohms.
12. Signal Ground, Negative loop return.

Dip Switches

1. ON: EFC output will be active when power is applied to the PCB.
1. OFF: EFC output will be active when power is applied to the A ON or B ON input.
2. ON: Applying power to the A ON input activates the EFC output and turns the Coil A output on.
2. OFF: Applying power to the A ON input only turns the Coil A output on.
3. ON: Applying power to the B ON input activates the EFC output and turns the Coil B output on.
3. OFF: Applying power to the B ON input only turns the Coil B output on.
4. Not Used

Factory Settings

Ramping Up, set for minimum delay.
 Ramping Down, set for minimum delay.
 Minimum Output, Set for 0.2 Amp.
 Maximum Output, Set for 1.00 Amp.

Factory Switch Settings

1. On
2. On
3. On
4. Not used



Fuses

- F1. Main fuse, 7.5A max, ATM-7-1/2.
- F2. Coil A and B Output fuse, 5A max, ATM-5
- F3. EFC output fuse, 2A max, ATM-2.

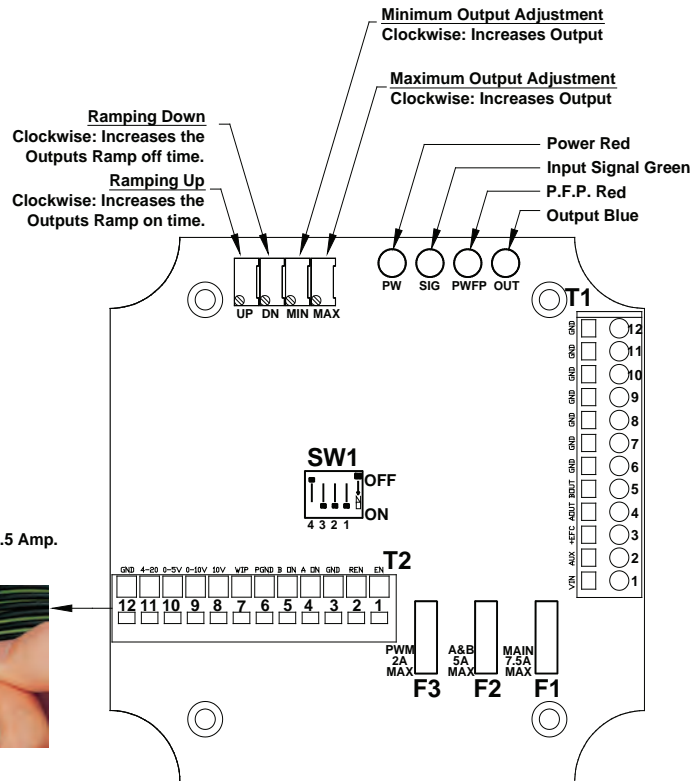

TYPICAL SYSTEM CONFIGURATION:

EC20400
&
Brand Series
36EFC or 38EFC

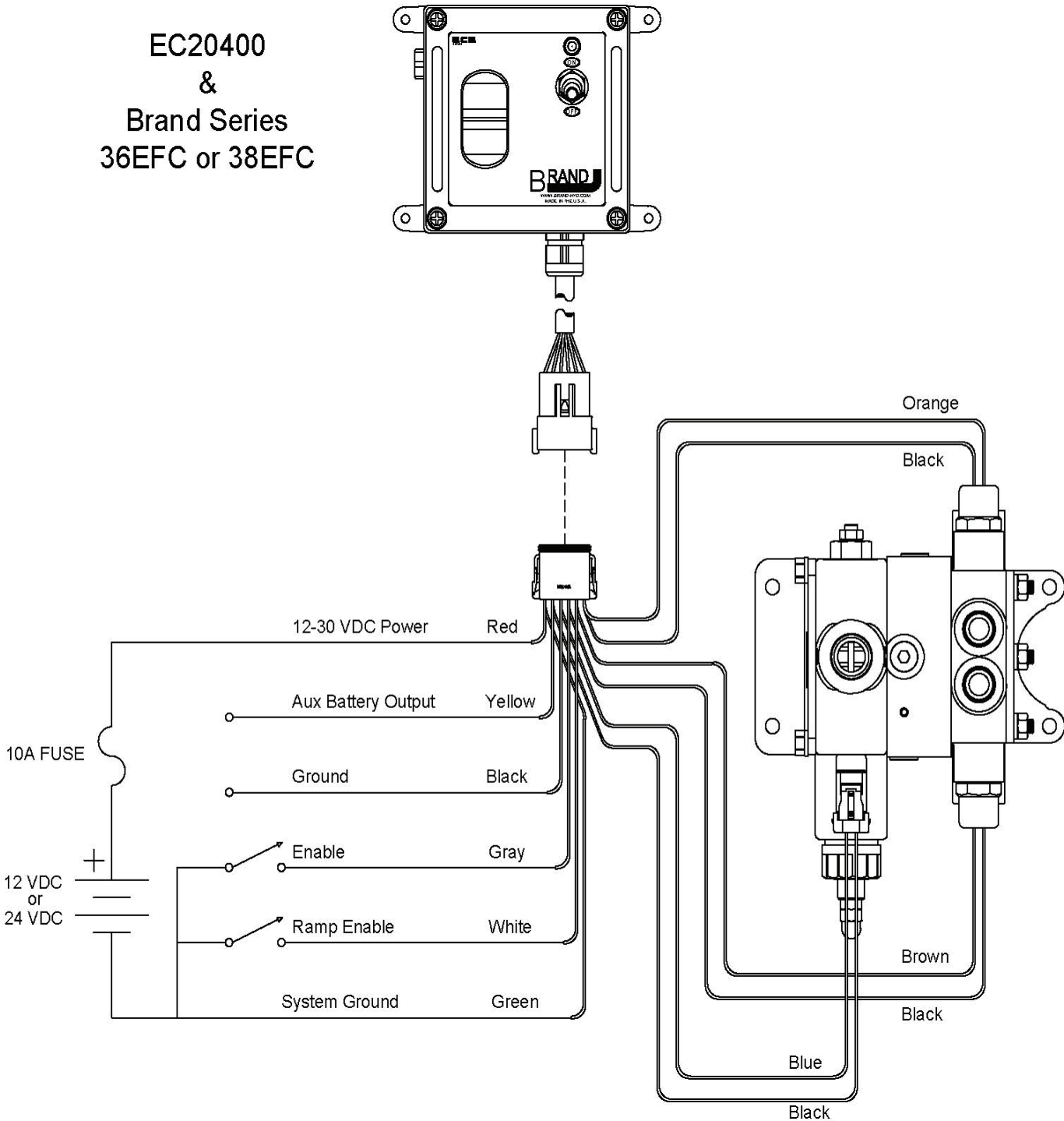

NOTE: Brand Hydraulics recommends a 10 amp fuse be placed within 18 inches of this controls power source. The fuse and power source are customer supplied parts. Valve is sold separately.

NOTE: Ensure that all unused wires are capped, and electrically isolated from each other and ground.

EC20400 Joystick Control

DIMENSIONAL DATA: inches & [millimeters]

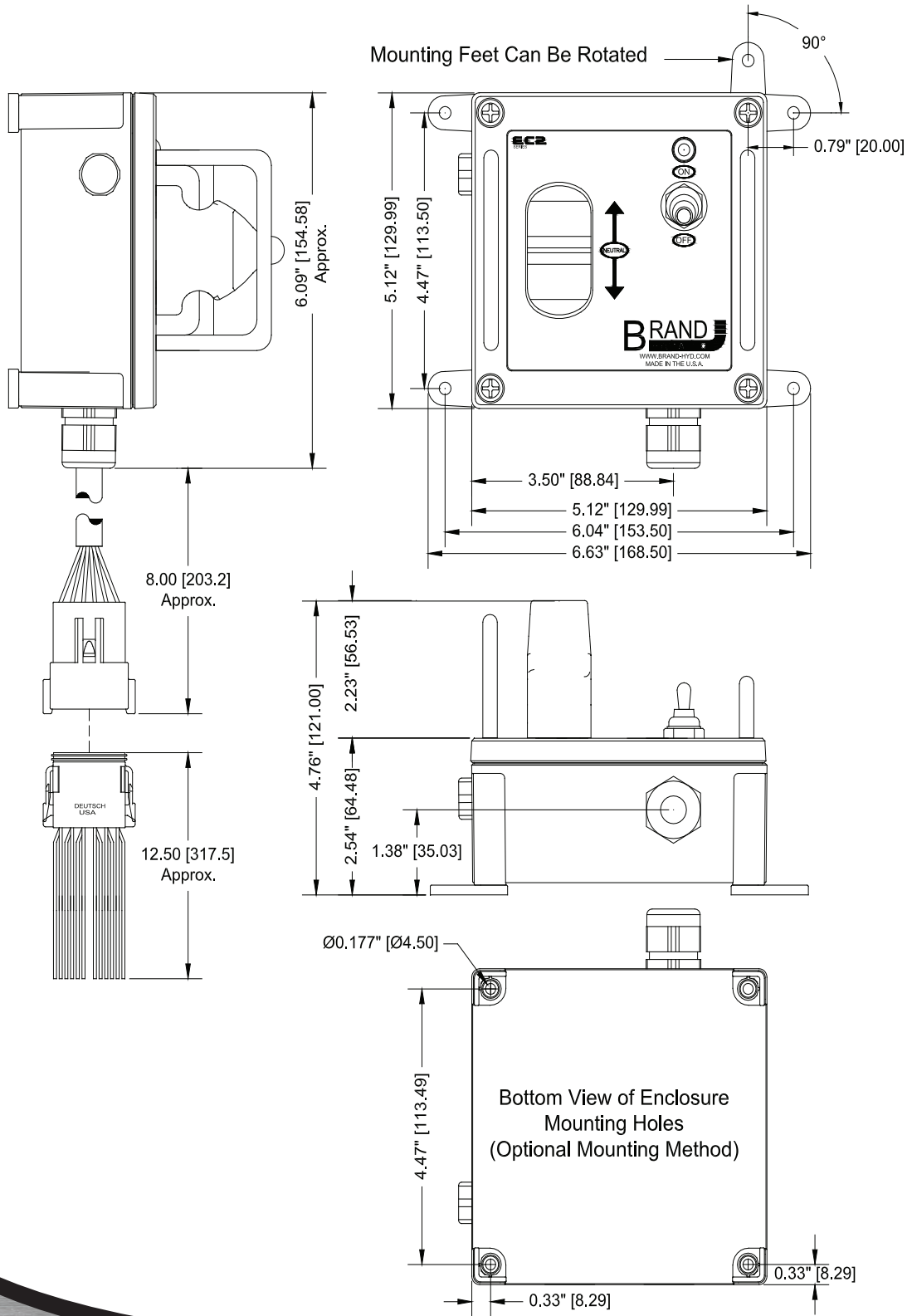

ADJUSTMENTS:

Minimum output or zero setting	Clockwise rotation increases minimum output 0 - 1.5 Amps
Maximum output	Clockwise rotation increases maximum output 0.05 - 2 Amps Maximum output will always be 50 mA greater than the minimum output
Ramping Down, or Fall Time	Clockwise rotation increases ramp time 0.1 - 12 Seconds
Ramping Up, or Rise Time	Clockwise rotation increases ramp time 0.1 - 12 Seconds

ADJUSTMENT PROCEDURE:

Adjustments are made by turning a trim pot screw. The trimmers are 25 turn, end to end devices. The trimmers have a built in slip clutches so over rotations do not damage them. It may be necessary to turn the adjustment screw several turns to observe a change in output. Start by adjusting the min output, and then adjust the max output to the desired level. The best way to fine tune adjustments is to observe the function response or speed. It is important to make adjustments in the following order.

1. Minimum output: Start by setting the master Potentiometer or input signal to zero. Turn the trimmer clockwise until the function begins to move. Now turn the trimmer back counter clockwise, one full rotation past the point of any visible movement.
2. Maximum output: Start by setting the master Potentiometer to the 100 position on the dial. Turn the trim pot counter clockwise to decrease function speed. Turn the trim pot clockwise to increase function speed. Function maximum speed will be limited to the max flow capabilities of your hydraulic system. Do not rotate the trim pot past the point of an observable increase in function speed.
3. Ramp up: This feature changes how quickly the valve can open. Clockwise turns increase the amount of delay. Counterclockwise turns decrease the amount of delay.
4. Ramp down: This Feature changes how quickly the valve can close. Clockwise turns increase the amount of delay. Counterclockwise turns decrease the amount of delay. Use discretion when making this adjustment, this will affect how quickly your function stops.

MIN/MAX Adjustments

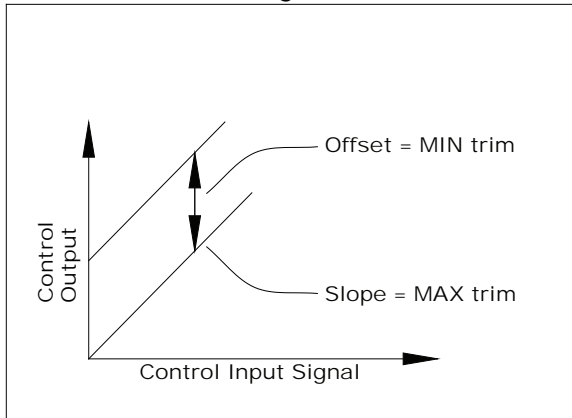

Ramping

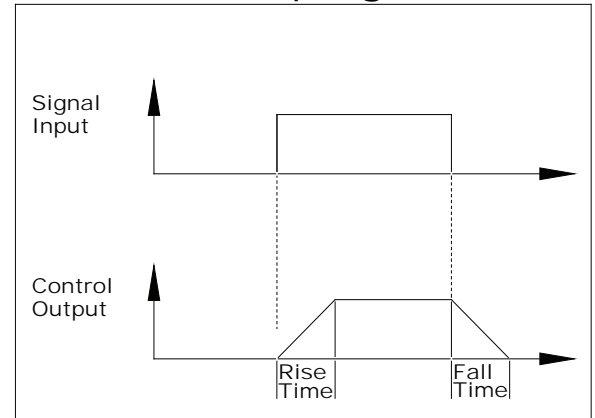

Output Current vs. Voltage Supply Fluctuation

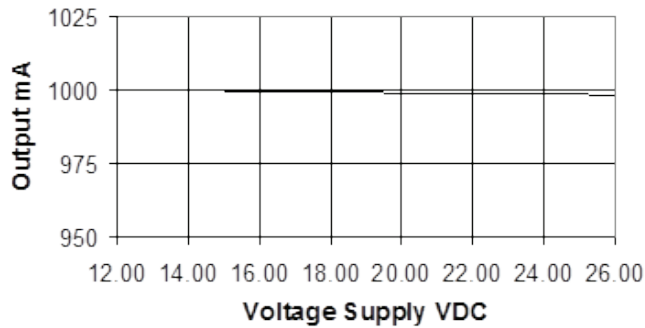

Output Regulation vs. Load Resistance (Set point 1 Amp, 26VDC Supply)

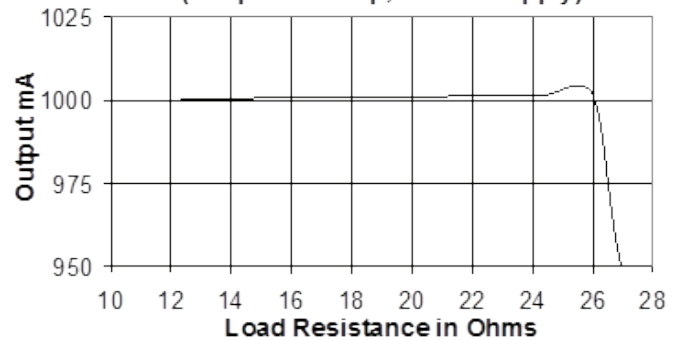

Output Current vs. Potentiometer Wiper Input

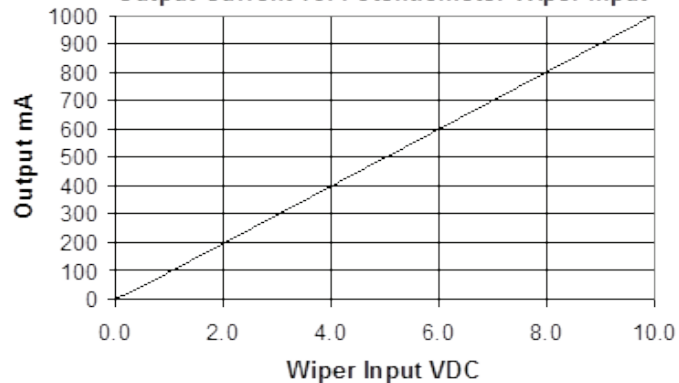

NOTE: Unless stated otherwise the above readings were taken at 25°C, with control connected to a 14.6V supply, and the output was set for 1 amp.

PARTS AND ACCESSORIES:

- E1907.....Water proof pressure and vapor release vent
 E1908.....Vent lock nut
 E1747.....Toggle switch, SPST, ON-NONE-OFF, #6 screw terminals
 E1844.....Switch boot seal, red
 E1902.....Mounting feet kit, includes 4 feet and 4 screws

Contact your local Brand Hydraulics distributor for pricing.

ATTENTION:**WARNING:**

- All used and unused wires should be secured and electrically isolated from each other and any other possible connections. Not doing so could result in personnel injury, fire, or even death. If you have questions regarding installation consult with your distributor, the factory or an electronic technician.

CAUTION:

- Only mount the EC20400 on flat surfaces. Mounting to uneven surfaces can cause mounting feet to break.
- Not designed for use in AC voltage systems. Use an AC to DC power supply consult factory for appropriate sizing.
- Values and ranges stated in the General Specifications and other areas of this data sheet are Absolute Maximum Ratings. Absolute Maximum Ratings indicate limits beyond which this device should not be used or damage to the device may occur. Operating Ratings and Ranges indicate conditions for which the device is functional. Devices operated beyond the Absolute Maximum Ratings and Ranges may void the devices warranty.
- Terminal block 2 pin 6 is to be used for the potentiometers ground only. Never use a potentiometer with a resistance lower than 2K Ohms. The resulting damages caused by excessive currents will not be repaired under warranty.
- Never apply voltage to the 4-20 mA signal input terminal. Never apply more than 5 V to the 0-5V signal input terminal. Never apply more than 10V to the 0-10V and potentiometer wiper input terminals. Doing so will void the controls warranty.

It is the purchaser's responsibility to determine the suitability of any Brand Hydraulics product for an intended application, and to insure that it is installed in accordance with all federal, state, local, private safety, health regulations, and codes and standards. Due to the unlimited variety of machines, vehicles, and equipment on which our products can be used, it is impossible for Brand Hydraulics to offer expert advice on the suitability of a product for a specific application. We believe that it is our customer's responsibility to undertake the appropriate testing and evaluation to prevent injury to the end user.

All product, product specifications and data are subject to change without notice to improve reliability, function or design or otherwise.