



**BRAND**  
**HYDRAULICS Co.**

Made in the Heartland of America  
Serving the World

Engineering & Manufacturing Solutions

**Specifications:**

- Rated for 3000 psi (207 bar).
- Rated for 0-30 gpm (0-113.6 lpm) max. priority flow.
- 30-Micron filtration recommended.
- Weight -BG, BGR & BGC = 5 lbs. (2.3 kg).

# BG

Non-Adjustable Constant Volume  
Priority Divider



PBGR501-3/4



ISO 9001:2008 WITH DESIGN  
Certificate #02.002.1



402.344.4434 • [www.brand-hyd.com](http://www.brand-hyd.com)

# BG Non-Adjustable Constant Volume Priority Divider

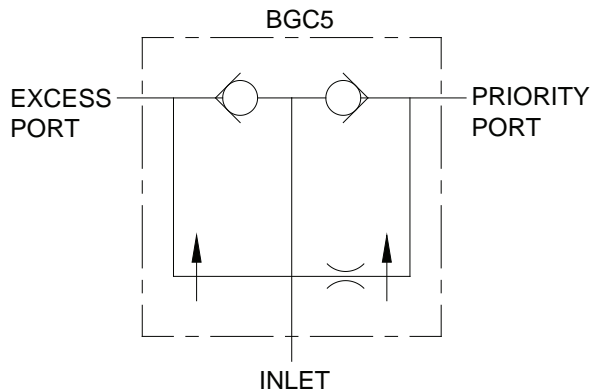
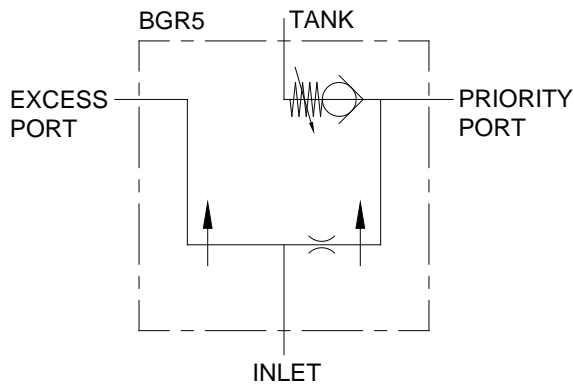
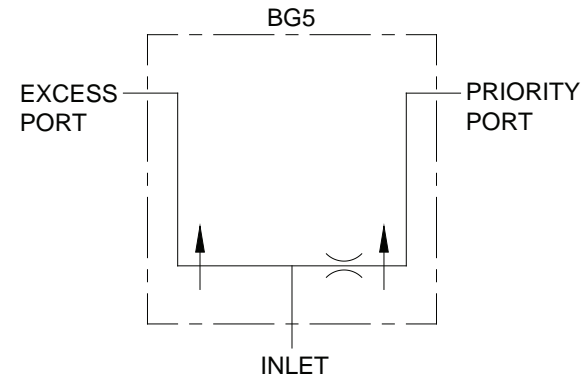

**PBGR501-3/4**

## MATERIALS:

- Cast Iron Body
- Buna N O'Rings
- Heat Treated Steel Spools
- Heat Treated Free Reverse Check Seat
- Heat Treated Relief Seat

## FEATURES:

- PRECISION GROUND HEAT TREATED SPOOL that assures long life.
- PRESSURE COMPENSATION for both outlet ports.
- PRIORITY FLOW IS PRESET at factory to customer requirements.
- EVERY BG IS TESTED for priority flow and pressure compensation.
- LARGE METERING SPOOL provides a greater area for the pressure differential to act upon.
- OPTIONAL FREE REVERSE FLOW allows fluid to move from the outlet port to the inlet port.
- OPTIONAL BALL SPRING RELIEF VALVE for priority flow relief.

**BG – GENERAL INFORMATION:**

The Brand, non-adjustable priority flow divider comes in three basic models BG5, BGR5 and BGC5. The BG series receive a single stream of fluid and divides it into two separate output streams. The priority port will maintain the same flow even with an increase or decrease in the input flow. The priority port size is 3/8" NPT for 0-8 gpm (0-30.2 lpm), 1/2" NPT for 8-16 gpm (30.2-60.5 lpm) and 3/4" NPT for 16-30 gpm (60.5-113.4 lpm).

**BG5** – is a non-adjustable priority divider that receives a single stream and divides it into a priority stream and an excess stream. The two outlet flows are pressure compensating and the sum of said flows equals the inlet flow. The priority flow setting must be specified when ordering.

**BGR5** – is very similar to the BG5 in that it is a non-adjustable priority divider, but in addition to the BG5's features it also provides a ball spring relief valve for the priority port. Adjustable relief is set to 1500 psi (103 bar) at the factory (standard setting). The relief flow dumps to its own drain port. The two outlet flows are pressure compensating and the sum of said flows equals the inlet flow. The priority flow setting must be specified when ordering.

**BGC5** – is very similar to the BG5 in that it is a non-adjustable priority divider, but in addition to the BG5's features it also provides free reverse flow for both outlet ports. Flow can travel in reverse through both outlet ports and is not metered as it travels in reverse. The non-metered flow travels past the poppet, down the center of the valve, past the orifice spool and then through the inlet. The two outlet flows are pressure compensating and the sum of said flows equals the inlet flow. The priority flow setting must be specified when ordering.

# BG Non-Adjustable Constant Volume Priority Divider

## BG - CREATING A MODEL CODE FOR BG'S:

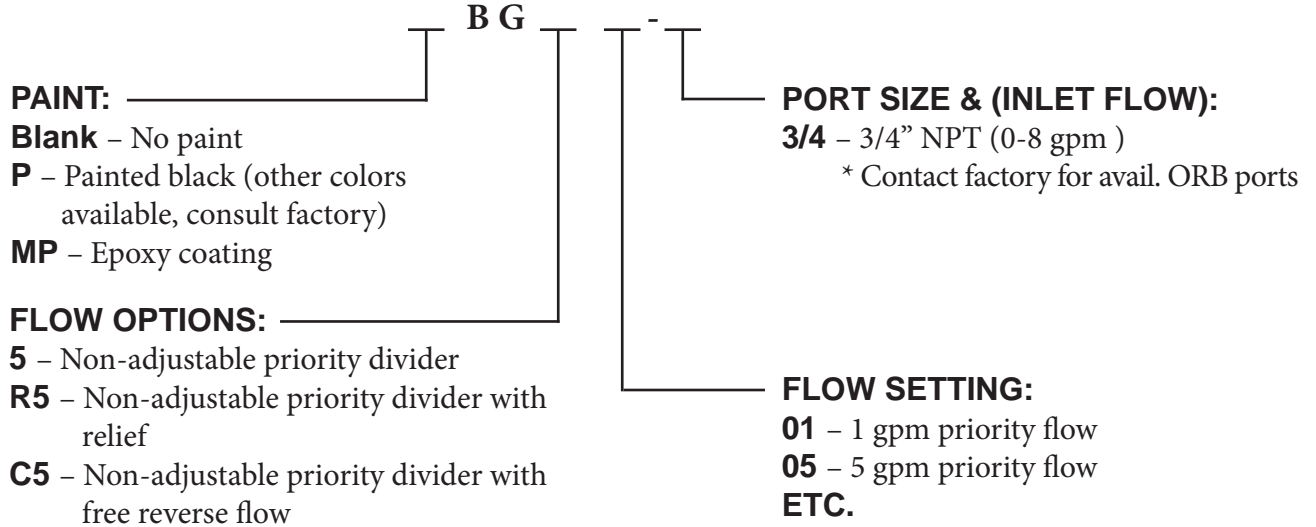

## BG - EXAMPLES OF COMMON MODEL CODES:

- BG503-3/4**.....Three gpm (11.3 lpm) priority setting, 3/4" inlet/excess ports and 3/8" priority port.
- BGR506-3/4**.....1500 psi (103 bar) relief setting, 6 gpm (22.7 lpm) priority setting, 3/4" inlet/excess ports, 3/8" priority port and 3/8" tank port.
- BGC504-3/4**.....Free reverse flow, 4 gpm (15.1 lpm) priority setting, 3/4" inlet/excess ports and 3/8" priority port.

## DIMENSIONAL DATA: Inches & [millimeters]

### BG

