



**BRAND**  
HYDRAULICS Co.

Made in the Heartland of America  
Serving the World

Engineering & Manufacturing Solutions

# Series 21

Direct Acting Solenoid Operated  
Stackable Directional  
Control Valve



P21A00020

## Specifications:

- 6 gpm Nominal Capacity.
- Pressure Ratings:
  - 4000psi (272 bar), Parallel
  - 3000psi (204 bar), Series
  - 400 psi (27 bar) max tank pressure.
- 6 sections max.
- 10 Micron Filtration Recommended.
- Assembly Torque = 85 inch-lbs. (9.6 N m)
- Spool Leakage = Less than 1.5 - 2.0 in3 (25 - 33 cc) at 1000 psi. (69 bar) per minute.
  - Weight -Inlet = 2.6 lbs. (1.2 kg).
  - Work section = 4.4 lbs. (2.0 kg).
  - Outlet = 2.2 lbs. (1.0 kg).
- Port Sizes -Inlet/outlet #6SAE (9/16-18).
  - Work Ports #6SAE (9/16-18).
  - Power Beyond #6SAE (9/16-18).



ISO 9001:2008 WITH DESIGN  
Certificate #02.002.1



402.344.4434 • [www.brand-hyd.com](http://www.brand-hyd.com)



# Series 21

Direct Acting Solenoid Operated  
Stackable Directional Control Valve

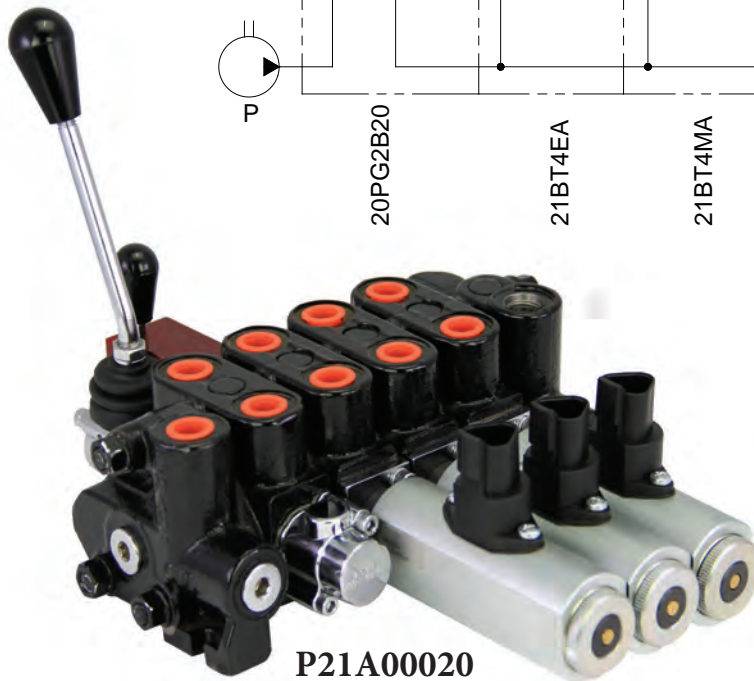
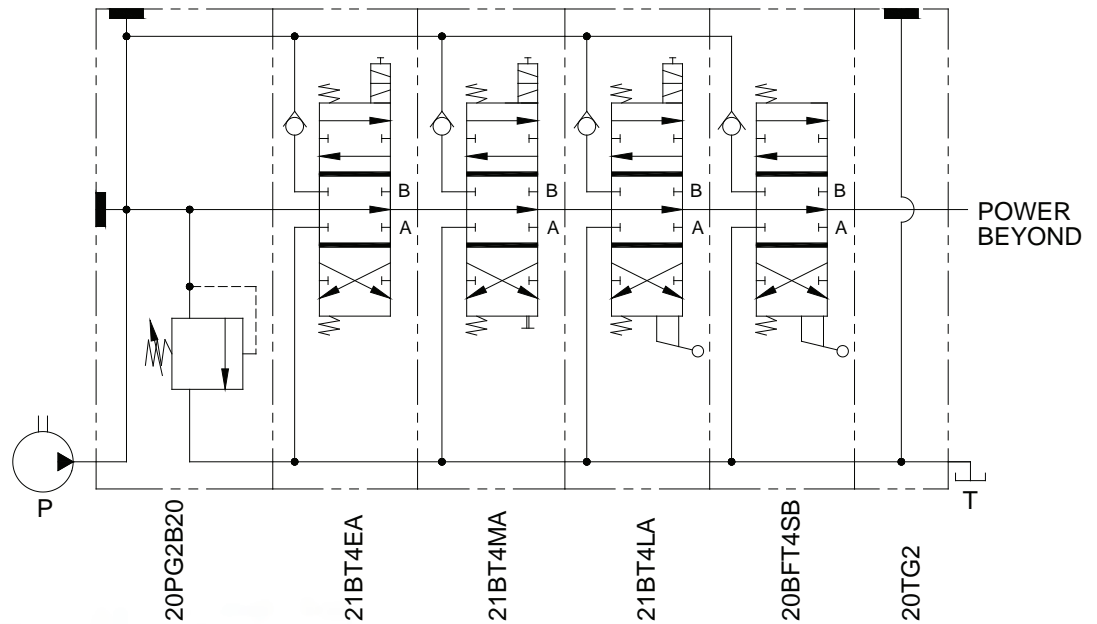

P21A00020

### MATERIALS:

- Cast Iron Body.
- Buna N O'Rings (standard).
- Stress Proof Tie Rods

### FEATURES:

- O'RING PORTS to eliminate leakage.
- POWER BEYOND CAPABILITY to fit your multi-valve circuits.
- PRECISION HONED SPOOL BORE provides consistent spool fit with low leakage.
- ENCLOSED SOLENOIDS & CONNECTIONS eliminate exposure to the elements.
- INDIVIDUAL LOAD CHECK built into each section to prevent the load from dropping when the spool is shifted.
- ALL SECTIONS & ASSEMBLIES ARE 100% TESTED including both internal & external leakage & flow tests.
- OPTIONAL LEVER HANDLES for manual control when power is lost.
- COMBINABLE WITH SERIES 20 MANUAL VALVE for increased versatility.

## SERIES 21 – GENERAL INFORMATION:

The Brand, Series 21 Direct Acting Solenoid Operated Stackable Directional Control Valves are assembled to meet our customer's requirements for up to six individual applications per assembly. Brand Hydraulics does not charge anything extra for this process, an assembly is priced solely on the overall sum of the prices of its components.

When assembled in their normal manner the Series 21 spool sections are in parallel. When the spools are in the neutral position flow passes by each spool and then onto the tank (outlet) port. If two or more spools are shifted simultaneously their work ports are in parallel. The oil flow will take the path of least resistance allowing lighter loads to move first.

### INLETS –

Can be provided with no relief, or an adjustable high lift relief (B). Standard inlets are end ported (1) which is not field convertible. The other optional inlets are machined with end, top (2) and side (3) ports, these two options are field convertible to all three ports. Option (4) is similar to option (2) except it also has a relief drain port.

### OUTLETS –

Are available end ported (1) which is not convertible to top or side porting. The other optional outlets are top (2) and side (3) ported, these two options are field convertible to all three ports. Options (2) and (3) are machined for power beyond and closed center cartridge. Specify (W) to receive the outlet assembled with power beyond cartridge. Specify (C) to receive the outlet assembled with closed center cartridge.

### WORK SECTIONS:

Note: Series 21 work sections can be combined with series 20 work sections on the same stack. (See series 20 literature for ordering information)

### SPOOL TYPE –

Open Center four-way (**O4**) connects ports A and B to tank in neutral. Tandem Center four-way (**T4**) blocks port A and B in neutral. Tandem Center, three-way (**T3**) powers a cylinder in one direction. Please note that closed center four-way operation can be obtained by using a tandem center four-way spool and a closed center plug in the assembly's outlet section.

### HANDLE OPTIONS –

- **Option (E)** specifies electric control only.
- **Option (L)** specifies electric control with manual lever override for use when power is unavailable. Please note the lever does not shift when valve's spool is shifted electrically.
- **Option (M)** specifies electric control and push pin style manual override. This option also allows the customer to shift the spool when power is unavailable.

# Series 21

Direct Acting Solenoid Operated  
Stackable Directional Control Valve

## VOLTAGE & COIL TERMINAL –

Option (A) is 12 Volt DC with DEUTSCH DT04-3P connector. Option (AF) is 12 volt DC with mating DEUTSCH connector and flying leads. Option (B) is 24 Volt DC with DIN 43650 connector. Option (BF) is 24 Volt DC with mating DIN connector and flying leads.

## ELECTRICAL SPECIFICATIONS

- Coil voltage: 12 or 24 VDC
- Duty cycle: 100%
- Coil power: 31 W at 68 °F [20 °C]
- Elect. connection: -IP 67 with connector  
-IP 50 without connector

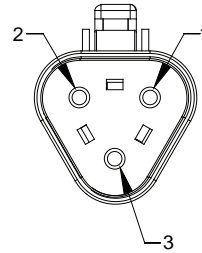

CONNECTOR SCHEME FOR  
BRAND PART NUMBER - E2287  
(DEUTSCH DT06-3S)

1. P TO B (B+)(BLUE)
2. P TO A (A+)(RED)
3. GROUND (C-)(BLACK)

Connector includes wire leads.

**ACCESSORY ITEMS** – All standard tie rod kits contain rods, lock washers and hex nuts. Please be sure to note correct tie rod torque spec of 85 inch pounds (9.6 N m).

Seal kits, power beyond kit, closed center kit and other accessory items are available; please see the “SERIES 21 COMPLETE LIST OF OPTIONS AND ACCESSORIES” section of this catalog, for model codes and descriptions of these items.

## SERIES 21 – GENERAL INFORMATION CONT...

**ASSEMBLY** – Model codes and list prices for complete assemblies will be issued by the factory, upon request of an authorized Brand Distributor. All model codes so issued become proprietary to the requesting distributor. Model codes so issued will not be descriptive in nature, but shall be of sequential numerical type. Individual sections and accessories can be purchased so that custom valve stacks may be assembled or modified outside the factory.

Paint (Optional) (P) painted black (other colors available, consult factory), (MP) epoxy coating.



**SERIES 21 – CREATING A MODEL CODE FOR SERIES 21:**

**INLET SECTION:**

**20PG**

**PORTING:**

- 1 – End port (not convertible)
- 2 – Top port (convertible to end or side port)
- 3 – Side port (convertible to top or end port)
- 4 – Top port with relief drain port (convertible to side or end port)

**RELIEF SETTING:**

- 15 - 1500 psi
- 20 - 2000 psi
- ETC...

**RELIEF:**

- OMIT – Not machined for relief
- B – Adjustable high lift relief

**SERIES 21 – CREATING A MODEL CODE FOR SERIES 21:**

**WORK SECTION:**

**20TG**

**PORTING:**

- 1 – End port (not convertible)
- 2 – Top port (convertible to end or side port)
- 3 – Side port (convertible to top or end port)

**OPTION:**

- OMIT – No options
- W – Power beyond cartridge used with top port (2) call out
- C – Closed center cartridge used with top port (2) call out

**SERIES 21 – CREATING A MODEL CODE FOR SERIES 21:**

**OUTLET SECTION:**

**21B**

**SPOOL TYPE:**

- T4 – Tandem four-way
- T3 – Tandem three-way
- O4 – Open four-way

**HANDLE OPTION:**

- E – Electric control only
- L – Lever control and electric control
- M – Push pin style manual override and electric control

**VOLTAGE & COIL TERMINAL:**

- A – 12 VDC Coil with DT04-3P connector
- AF – 12 VDC Coil with mating DEUTSCH connector and flying leads
- B – 24 VDC Coil with DIN 43650 connector
- BF – 24 VDC Coil with with mating DIN connector and flying leads



# Series 21

Direct Acting Solenoid Operated  
Stackable Directional Control Valve

**MANUAL WORK SECTION:**

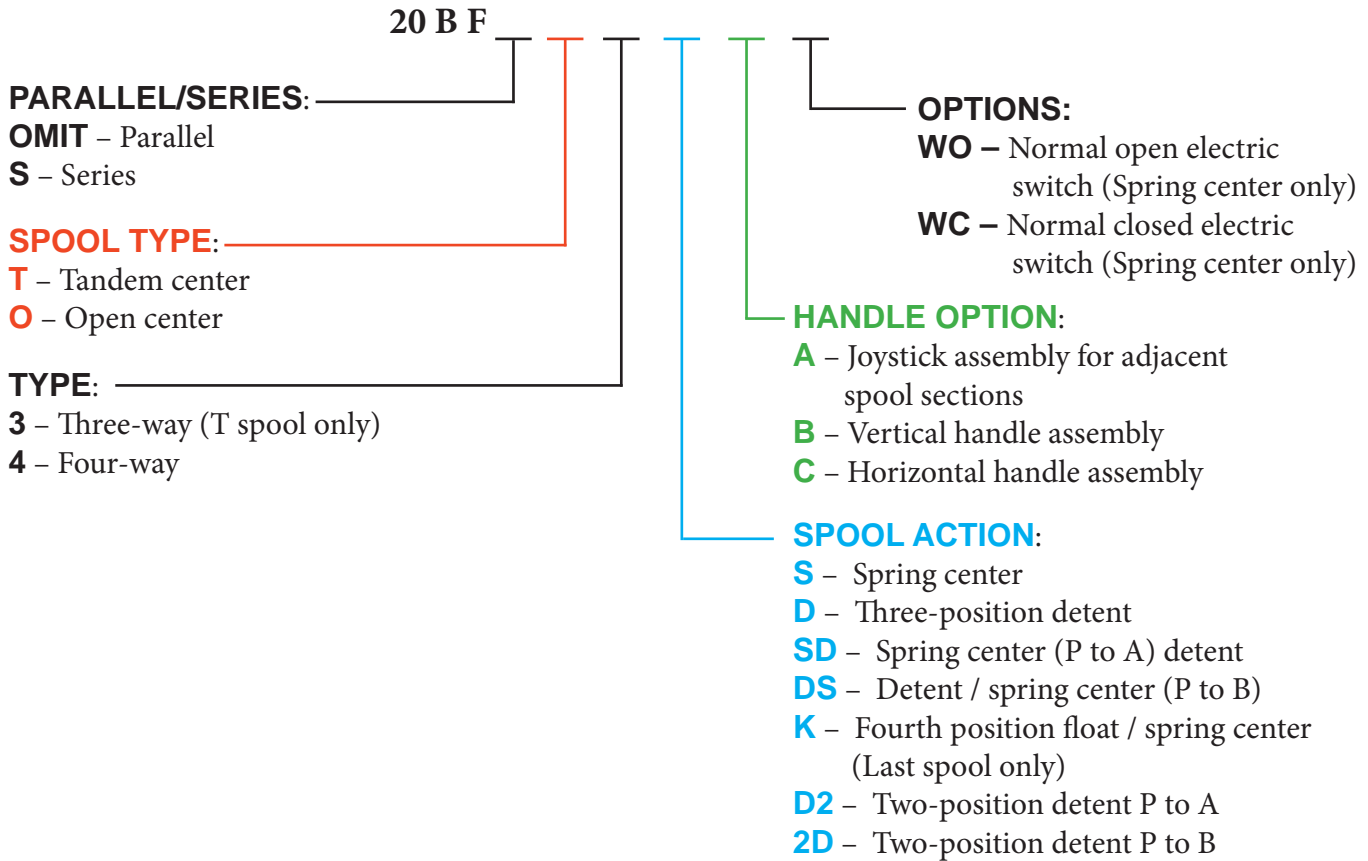

\*\*Note: Series 21 work sections can be combined with series 20 work sections on the same stack.

**SERIES 20 – EXAMPLES OF COMMON MODEL CODES:**

**INLET SECTIONS**

**20PG1**.....Inlet section plain, no relief, end ported.

**20PG1B20**.....Inlet section, end ported, and adjustable high lift relief set at 2000 psi.

**OUTLET SECTIONS**

**20TG1**.....Plain, end ported.

**20TG2W**.....Top ported outlet with power beyond cartridge, convertible to end ported.

**WORK SECTIONS**

**21BO4EA**.....Open center, four-way, spring to center and 12 volt DC coil.

**21BT4EA**.....Tandem center, four-way, spring to center and 12 volt DC coil.

**21BT4LA**.....Tandem center, four-way, spring to center, manual lever override and 12 volt DC coil.

**SERIES 20 – EXAMPLES OF COMMON MODEL CODES:**

- 21BT4MAF**.....Tandem center, four-way, spring to center, push pin style manual override, 12 volt DC coil and DEUTSCH DT06-3S connector with 13” wire leads.
- 21BO4MA**.....Pilot operated double lock valves, open center, four-way, spring to center, push pin style manual override and 12 volt DC coil with DEUTSCH DT04-3P connector.

**TIE ROD KITS**

- 20TR1**.....Tie rod kit for valve stack containing a standard inlet, outlet and one spool section.
- 20TR2**.....Tie rod kit for valve stack containing a standard inlet, outlet and two spool sections.

**STANDARD ASSEMBLY MODEL CODES:**

- 21A1**.....Single spool assembly, tandem center four-way, spring to center action, no relief 12 Volt DC Solenoid. End ported inlet and outlet.
- 21AB1**.....Same as above but with an adjustable spring relief added and set at 2000 psi.
- 21A2**.....Two spool assembly, tandem center four-way, spring to center action, no relief, and with 12 Volt DC Solenoid. End ported inlet and outlet.
- 21AB2**.....Same as above but with an adjustable spring relief added and set at 2000 psi

Standard assemblies are available with up to 6 spool sections using the model code format outlined above for the one and two spool assemblies.

**SERIES 20 – COMPLETE LIST OF OPTIONS AND ACCESSORIES:**

- 20ASB**.....Series block allows the customer to shift multiple work sections independently without losing fluid to the tank core. The down side to this section is that pressures are additive and the pressure rating of valve is reduced to 3000 psi (207 bar) because the tank core is seeing system pressure. This section must be installed between two spool sections to put them in series. (0.656” [16.7mm] casting width) Note: Inlet section with relief (“B” option) must have porting option”4”
- 20BFMIC**.....Mid-inlet combined flow.
- 20BFMIS**.....Mid-inlet split flow.

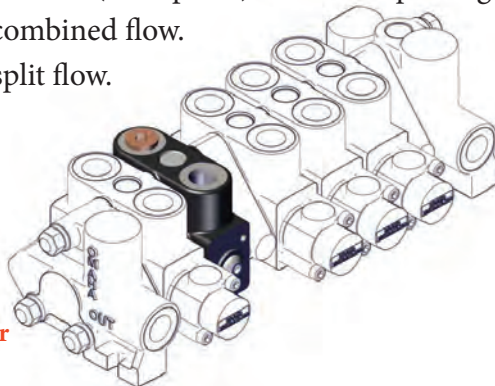

External dimensions are the same for all kits listed above.



# Series 21

Direct Acting Solenoid Operated  
Stackable Directional Control Valve

## SERIES 20 – COMPLETE LIST OF OPTIONS AND ACCESSORIES:

**20BFMICB\_**.....Mid-inlet combined flow with relief. Order as per example: 20BFMICB25 – Mid-inlet combined flow with 2500 psi relief setting. Relief is set in 100 psi increments.

**20BFMISB\_**.....Mid-inlet split flow with relief. Order as per example: 20BFMISB25 – Mid-inlet split flow with 2500 psi relief setting. Relief is set in 100 psi increments.

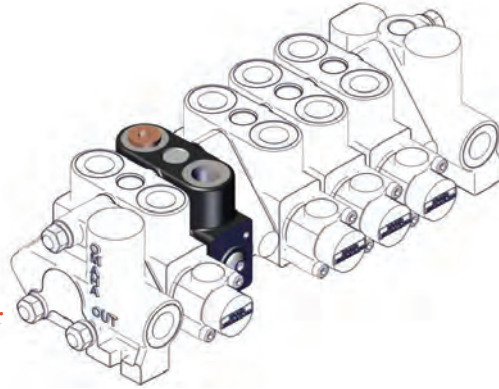

External dimensions are the same for all kits listed above.

**20TR\_**.....Tie rod kits, specify number of spool sections in valve assembly, i.e. 3 spool sections in valve assembly, requires using 20TR3 tie rod kit. Please note that when using extra items in the assembly, such as series blocks, drain blocks etc., the tie rod kit must have its length extended.

### Seal Kits:

**21AK**.....Replacement seal kit for work section.

**21BK**.....Seal kit, contains seals for use in between work sections.

**20CK**.....Replacement seal kit for inlet section.

**20DK**.....Replacement seal kit for outlet sections.

Please feel free to contact the factory with your ideas regarding custom options or accessories, we will be happy to review them to see if they can be put into production for your assemblies.



SERIES 21 – FLOW AND PRESSURE INFO:

Neutral Flow Pressure Drop

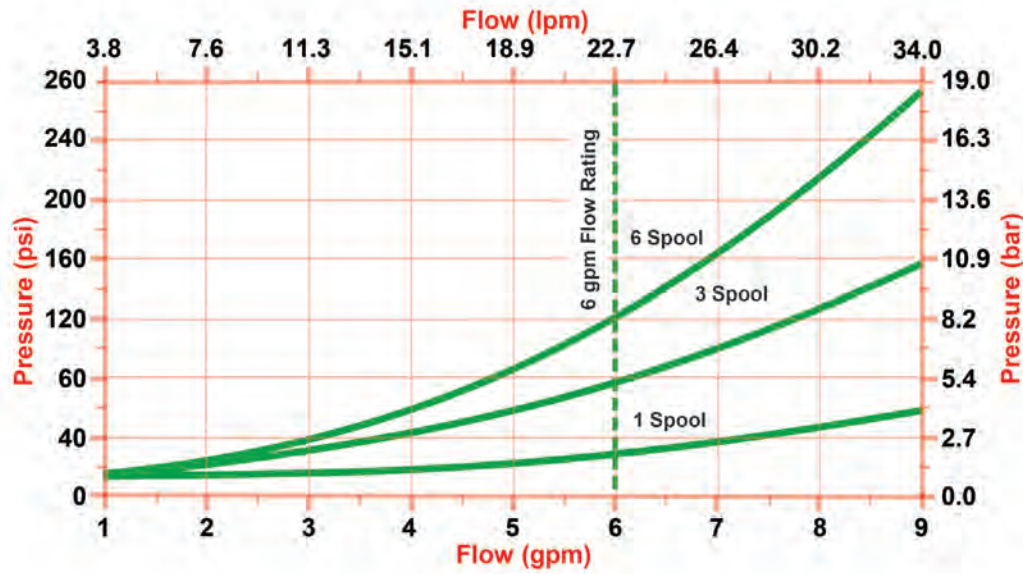

Pressure Drop VS. Flow for P to A or B

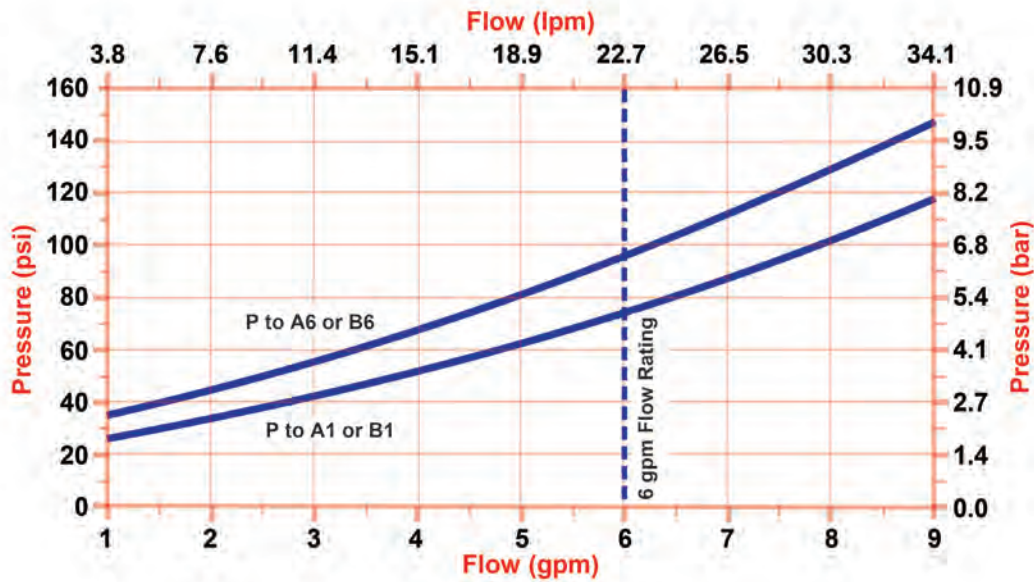

# Series 21 Direct Acting Solenoid Operated Stackable Directional Control Valve

## SERIES 21 – FLOW AND PRESSURE INFO:

Pressure Drop VS. Flow for A or B to T

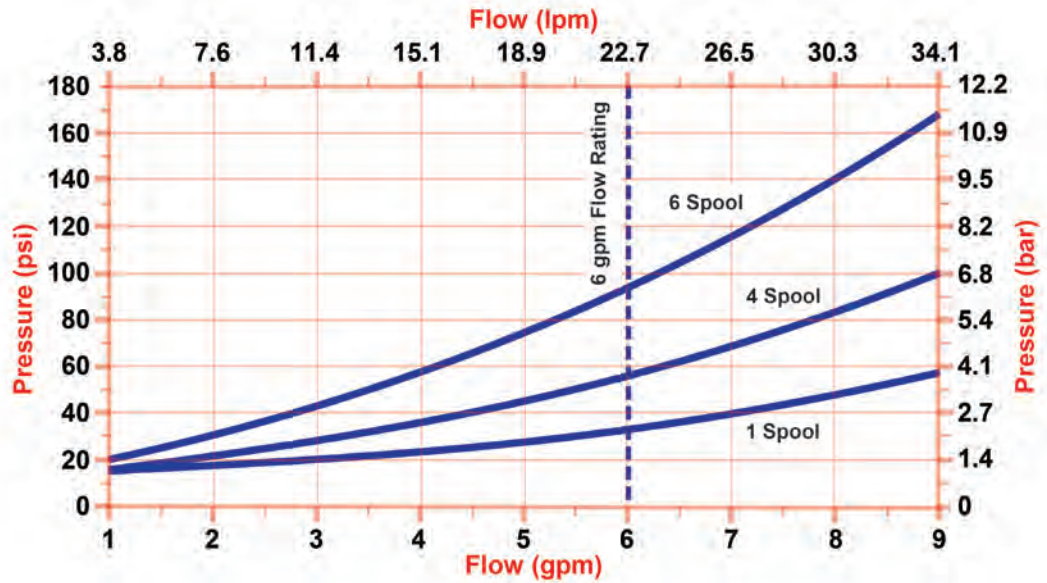

Pressure VS. Flow for S21 Inlet Relief

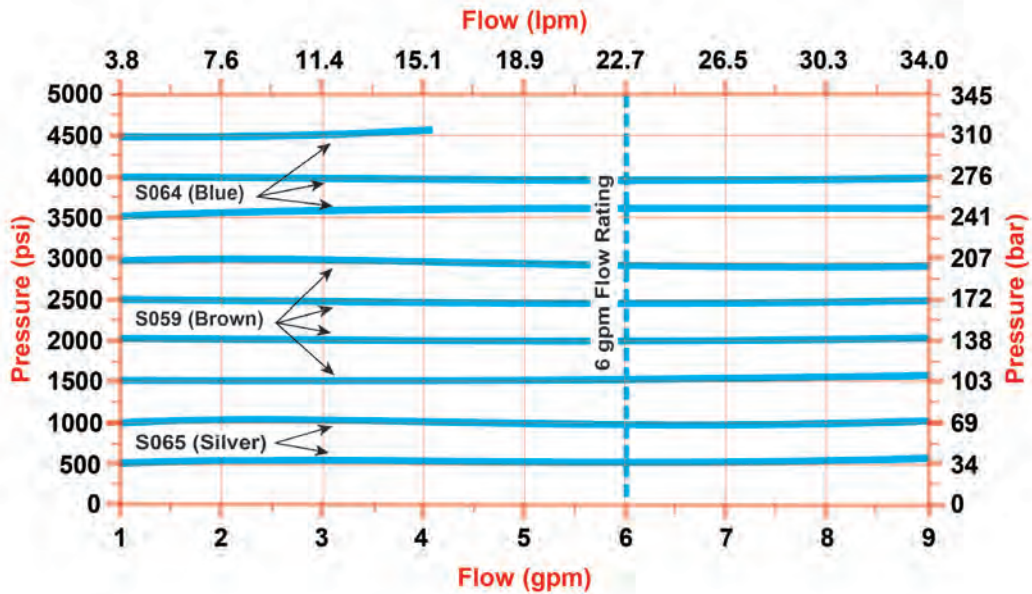



## DIMENSIONAL DATA: inches & [millimeters]

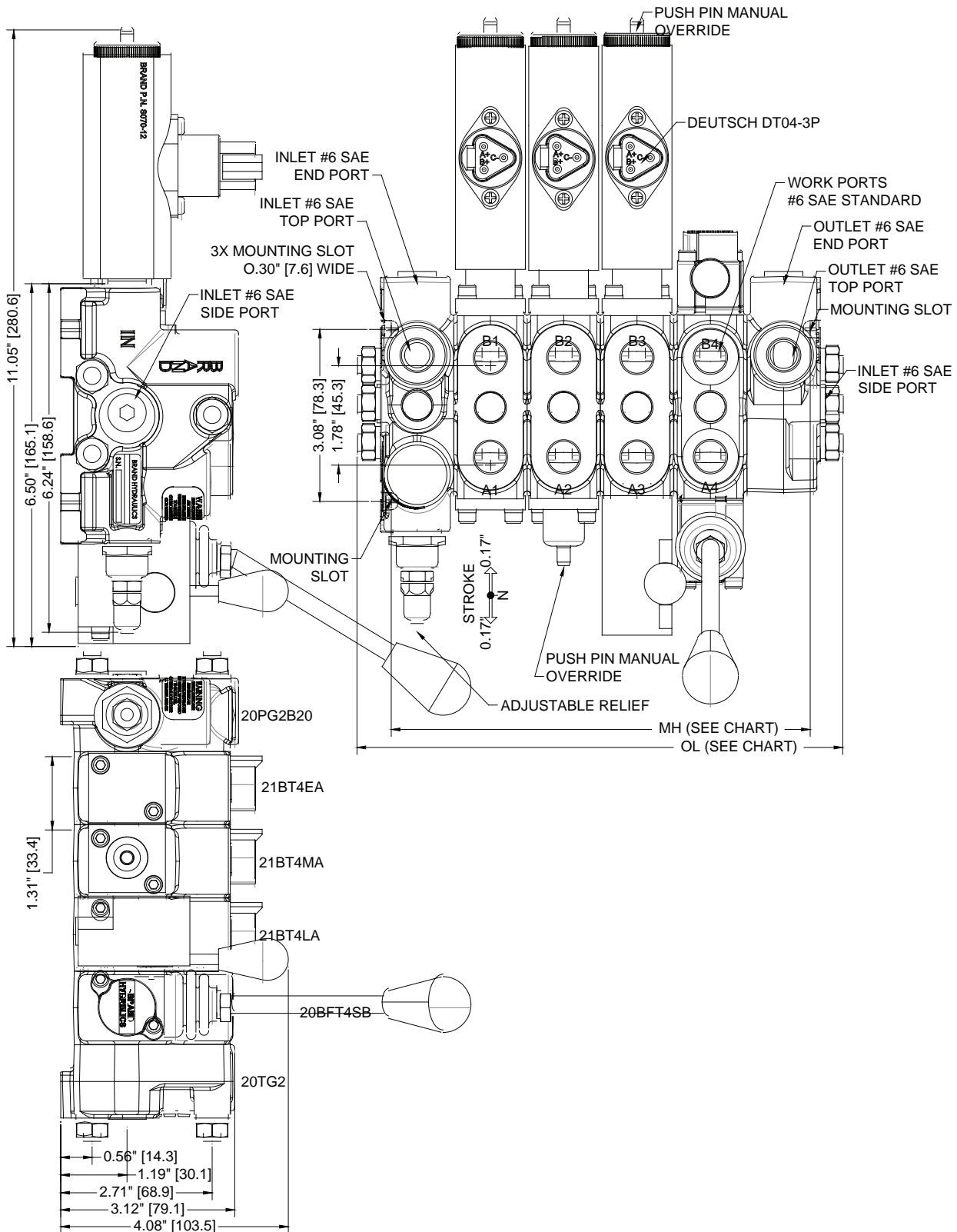

# Series 21 Direct Acting Solenoid Operated Stackable Directional Control Valve

**VALVE ASSEMBLY ARRANGEMENT:**

**PRICE**

(P)	P21A (Painted black) _____	
(MP)	MP21A (Epoxy coating) _____	
	21A _____	
INLET	20PG _____	
SPOOL #1	21B _____	
SPOOL #2	21B _____	
SPOOL #3	21B _____	
SPOOL #4	21B _____	
SPOOL #5	21B _____	
SPOOL #6	21B _____	
OUTLET	20TG _____	
MISC.	_____	
TIE ROD	20TR _____	
	(Torque to 85 inch lbs)	
ASSEMBLY	21A _____	LIST \$ _____

**DISTRIBUTOR:** \_\_\_\_\_

**NAME:** \_\_\_\_\_

**EMAIL:** \_\_\_\_\_ **PHONE:** \_\_\_\_\_

**ADDRESS:** \_\_\_\_\_

**CITY:** \_\_\_\_\_ **STATE:** \_\_\_\_\_ **ZIP:** \_\_\_\_\_ **DATE:** \_\_\_\_\_

