

Wireless Radio Controls

Installation and Operation Manual

Models:

Transmitter: V0400xxxxxx

Receiver: RP01000003

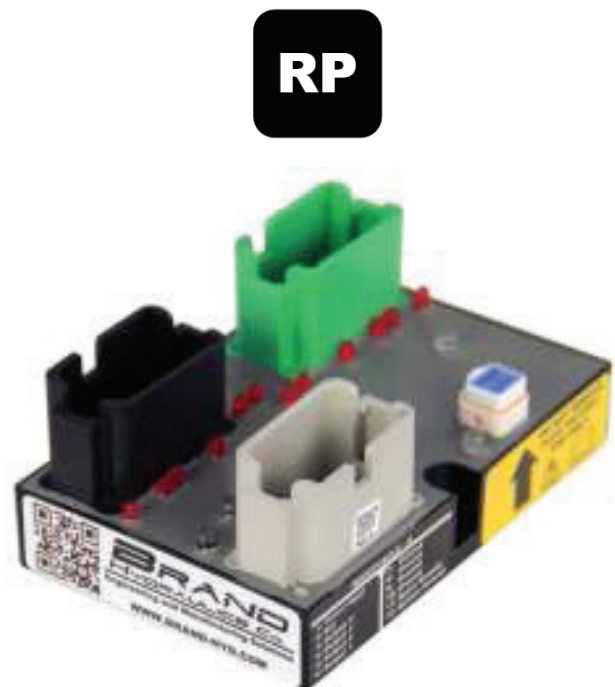

**Engineering and Manufacturing Solutions
Designed and Assembled in the U.S.A.**

IMPORTANT SAFETY INFORMATION

About this Manual

This manual provides detailed installation and usage instructions for the Wireless Radio Control Models listed. Only qualified electricians and technicians who are familiar with these types of electronic controls and wiring practices should install the Wireless Radio Remote Controls. The usage information in this manual is intended for the system owner/operator.

Detailed technical specifications for each product model can be found on the data sheet.

www.brand-hyd.com

Save These Instructions

This manual contains important safety, installation and operating instructions for the models listed on this document. The following symbols are used throughout this manual to indicate potentially dangerous conditions or mark important safety instructions:



WARNING:

Indicates a potentially dangerous condition. Use extreme caution when performing this task.



NOTE:

Indicates a procedure or function that is important for the safe and proper operation of the device.

Read the *Government Regulations* and *Warning! Safety First* sections of this manual prior to operating this system.



Failure to heed this information can result in death, personal injury or property damage and may also result in the illegal use of the system beyond its intended purpose.

Safety Information

- Read all of the instructions and cautions in the manual before beginning installation.
- Disconnect all sources of power to the receiver before installing.
- There are no fuses inside the transmitter or receiver. Do not attempt to repair.
- Install external fuses as noted and required.

Installation Safety Precautions

- Use insulated tools when working with batteries.
- Only replace transmitter batteries with new ones.
- Only replace transmitter batteries with EXACT type and part number
- Use properly sized conductors and fuses.
- The Wireless Radio Remote Control Models listed are to be connected to DC circuits only.
- A means shall be provided to ensure power disconnection from the power supply feeding the receiver. This disconnection shall be incorporated in the fixed wiring.
- A circuit current protection device must be installed within 12 inches of the power supply.



Brand Hydraulics Co. ALWAYS takes safety into consideration when designing its products. The Operation Manual, Data Sheet and decals on the product warn of hazards, and should be read and observed closely prior to using the product.



A battery can present a risk of electrical shock or burn from large amounts of short-circuit current, fire, or explosion from vented gases. Observe proper precautions.



When replacing batteries, use properly specified sizes, types, and ratings based on application and system design.



Proper disposal of batteries is required. Refer to local regulations or codes for requirements



It is the responsibility of the operator to read and understand the Operation Manual and other information provided, and use correct operating procedures.



ALWAYS maintain a safe distance from electric power lines and avoid contact with any electrically charged conductor. It is not necessary to make direct contact with a power line for power to ground through the structure of a machine. Accidental contact can result in electrocution.

GETTING STARTED

Thank you for selecting Brand Hydraulics Co. Wireless Radio Remote Controls. Our wireless controls are built with high quality long life components that are designed for use in harsh environments. We use the latest wireless and microprocessor technology including a 32-bit ARM-Core microprocessor. Our unique network design allows for operation of multiple units in the same location without interfering with each other.

V Series Transmitters

The conformal coated V Series are ergonomic, durable, sealed and easy to use radio remote transmitters. All exposed components on the transmitter are made from non corrosive materials. This transmitter is designed with Direct Sequence Spread Spectrum (DSSS) modulation for superior performance.

RP100 Series Receivers

The fully encapsulated RP Series are compact, durable, sealed and easy to install radio receivers. All exposed components on the receiver are made from non corrosive materials. This receiver is designed with Direct Sequence Spread Spectrum (DSSS) modulation for superior performance. It is a perfect complement to the Brand Series 21, Series 36 and Series 38 stackable directional control valves. Other control valves or solenoids meeting the appropriate specifications may be controlled as well.

The features of the transmitter are shown below.



1 – Power ON Button

The “ON” button will send a message to the receiver placing it in the “ON” state. All function buttons on the transmitter will become operational.

2 - Power OFF Button

The “OFF” button will send a message to the receiver placing it in the “OFF” state. All function buttons on the transmitter will become non-operational.

3 – Transmit Indicator LED

This LED will flash every time a message is sent.

4 – Low Battery Indicator LED

This LED will flash during a transmit when the battery is in need of replacement.

5 – Function Buttons

The V400 Series has 14 buttons. When a function button is pressed the receiver output will be active until the function button is released.

6 – Seal Skirt

Protective skirt that surrounds the transmitter and seals the enclosure.

7 – Compliance Label

FCC and IC numbers. Do not remove this label.

8 – Product Label

Do not remove this label. Use this information when calling for technical support

The features of the receiver are shown below.

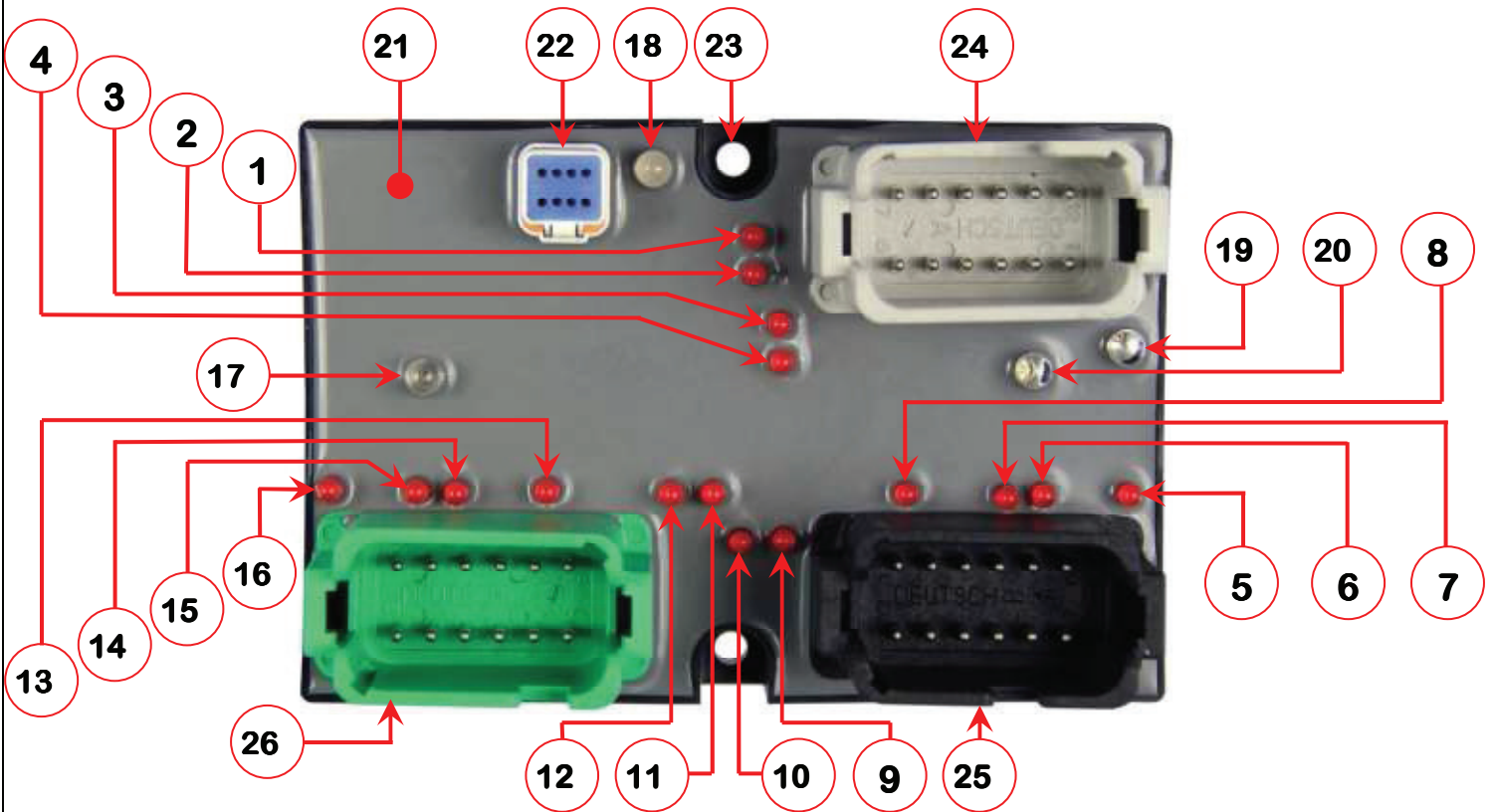

1 – Output 1 (Red)

This LED will be continuously illuminated when an output is being activated.

2 – Output 2 (Red)

This LED will be continuously illuminated when an output is being activated.

3 – Output 3 (Red)

This LED will be continuously illuminated when an output is being activated.

4 – Output 4 (Red)

This LED will be continuously illuminated when an output is being activated.

5 – Output 5 (Red)

This LED will be continuously illuminated when an output is being activated.

6 – Output 6 (Red)

This LED will be continuously illuminated when an output is being activated.

7 – Output 7 (Red)

This LED will be continuously illuminated when an output is being activated.

8 – Output 8 (Red)

This LED will be continuously illuminated when an output is being activated.

9 – Output 9 (Red)

This LED will be continuously illuminated when an output is being activated.

10 – Output 10 (Red)

This LED will be continuously illuminated when an output is being activated.

11 – Output 11 (Red)

This LED will be continuously illuminated when an output is being activated.

12 – Output 12 (Red)

This LED will be continuously illuminated when an output is being activated.

13 – Output 13 (Red)

This LED will be continuously illuminated when an output is being activated.

14 – Output 14 (Red)

This LED will be continuously illuminated when an output is being activated.

15 – Output 15 (Red)

This LED will be continuously illuminated when an output is being activated.

16 – Output 16 (Red)

This LED will be continuously illuminated when an output is being activated.

17 – Reset (Yellow)

This LED will flash occasionally if the receiver detects an error and automatically resets itself. Upon restart, the control will return to its original state and should not be of concern unless it happens continuously.

18 – Transmit (Green/Red)

This LED will flash green every time a message is received. If continuously red, a network error has occurred and a reset is required. If flashing orange, pairing was successful.

19 – Power Good (Green)

This LED will be continuously lit when power is provided to the receiver.

20 – Reverse Polarity (Amber)

This LED will be continuously lit when power is connected in the reverse direction. The receiver will not function in the state.

21 – Encapsulated

Waterproof encapsulate completely sealing the circuit board inside.

22 – Programming Connector

Factory Use Only! Do NOT remove this plug!

23 – Mounting Holes

The receiver has (2) mounting holes. Mount with #8 Button Head Type Screw

24 – Power/Output Receptacle – A

Receptacle – A, Gray.

25 – Output Receptacle – B

Receptacle – B, Black.

26 – Output Receptacle – C

Receptacle – C, Green.

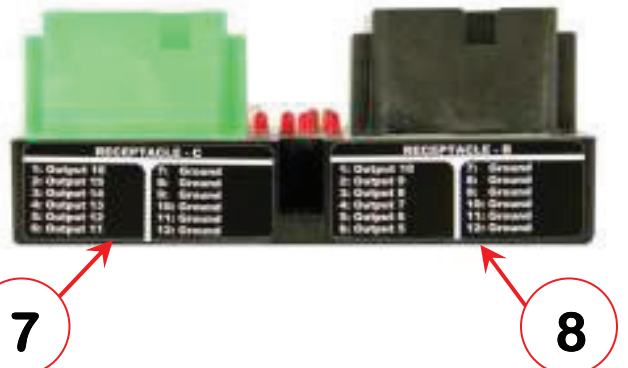
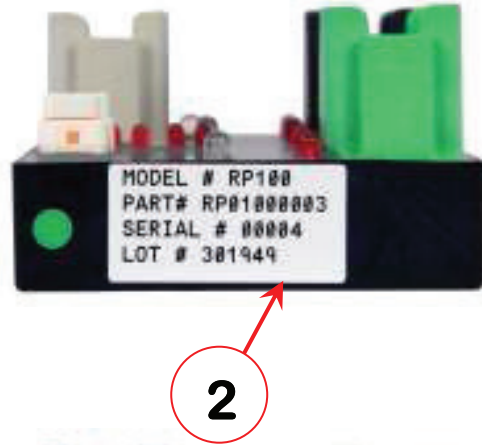

1 – Compliance Label

FCC and IC numbers. Do not remove this label.

2 – Product Label

Do not remove this label. Use this information when calling for technical support.

3 – Enclosure

Plastic enclosure

4 – Company Information Label

Website and QR code information

5 – Connector Pin Out Label

Description of each pin on Receptacle – A

6 – Connector Warning Label

Do not remove.

7 – Connector Pin Out Label

Description of each pin on Receptacle – C

8 – Connector Pin Out Label

Description of each pin on Receptacle – B

REGULATORY INFORMATION



This section contains important information for safety and regulatory requirements.

FCC ID: VW4A091729

IC: 11019A-091729



FCC requirements:

This device complies with part 15 of the FCC Rules. Operation is subject to the following two conditions:

1. This device may not cause harmful interference, and
2. This device must accept any interference received, including interference that may cause undesired operation.

IMPORTANT: Modifications not expressly approved by the party responsible for compliance could void the user's authority to operate this equipment.

This equipment has been tested and found to comply with the limits for a Class B digital device, pursuant to Part 15 of the FCC rules. These limits are designed to provide reasonable protection against harmful interference in a residential installation. This equipment generates, uses, and can radiate radio frequency energy and, if not installed and used in accordance with the instruction manual, may cause harmful interference to radio communication. However, there is no guarantee that interference will not occur in a particular installation. If this equipment does cause harmful interference to radio or television reception, which can be determined by turning the equipment on and off, the user is encouraged to try to correct the interference by one or more of the following measures:

- Reorient or relocate the receiver.
- Increase the separation between the equipment and receiver.
- Consult the dealer or an experienced radio/TV technician for assistance.

INSTALLATION

RP Series Receiver



Failure to properly install this product may result in costly damages, personal injury, or both.

- 1) Disconnect power to receiver prior to beginning installation
- 2) Select and test a suitable location for the receiver prior to permanent installation.
- 3) Verify that wires can be properly routed to the select location prior to permanent installation.
- 4) Mount receiver using both mounting holes
- 5) Connect connector plugs to respective receptacle on the receiver
- 6) Send power to the receiver and verify the proper LED indicators are illuminated.



Only mount the receiver on flat surface to prevent damage to the enclosure



Make sure connector plugs are securely seated in each receptacle.



All power/output receptacles and plugs are keyed and color coded. Take note of this as you install them. Do not force plugs into the wrong receptacles.

V Series Transmitter

The transmitter was shipped from the factory with a battery preinstalled. Turning the power button ON should be the only thing required for operation after the receiver is installed.



It is unknown how long the transmitter will be in inventory prior to the end user. This unknown time frame may cause the factory battery to have a shorter lifespan.



If after installation the transmitter does not work with the receiver try pairing the transmitter with the receiver. See "Pairing" section in this manual for details.

RP100 Connector Details:

RECEPTACLE PINOUT "C"	
1.	OUTPUT 16
2.	OUTPUT 15
3.	OUTPUT 14
4.	OUTPUT 13
5.	OUTPUT 12
6.	OUTPUT 11
7.	GROUND
8.	GROUND
9.	GROUND
10.	GROUND
11.	GROUND
12.	GROUND

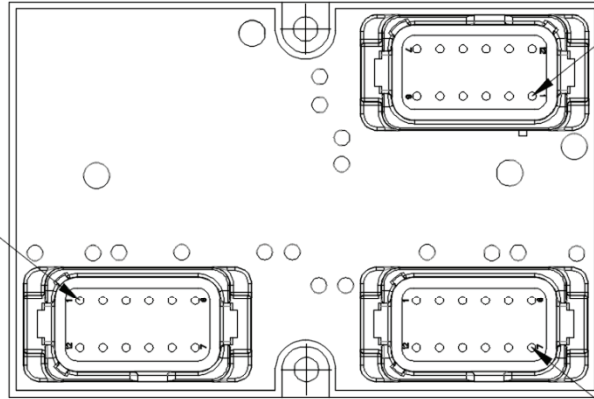

RECEPTACLE PINOUT "A"	
1.	POWER
2.	N/C
3.	OUTPUT 4
4.	OUTPUT 3
5.	OUTPUT 2
6.	OUTPUT 1
7.	GROUND
8.	GROUND
9.	GROUND
10.	GROUND
11.	N/C
12.	SYSTEM GROUND

RECEPTACLE PINOUT "B"	
1.	OUTPUT 10
2.	OUTPUT 9
3.	OUTPUT 8
4.	OUTPUT 7
5.	OUTPUT 6
6.	OUTPUT 5
7.	GROUND
8.	GROUND
9.	GROUND
10.	GROUND
11.	GROUND
12.	GROUND

RP100 Dimensions Details:

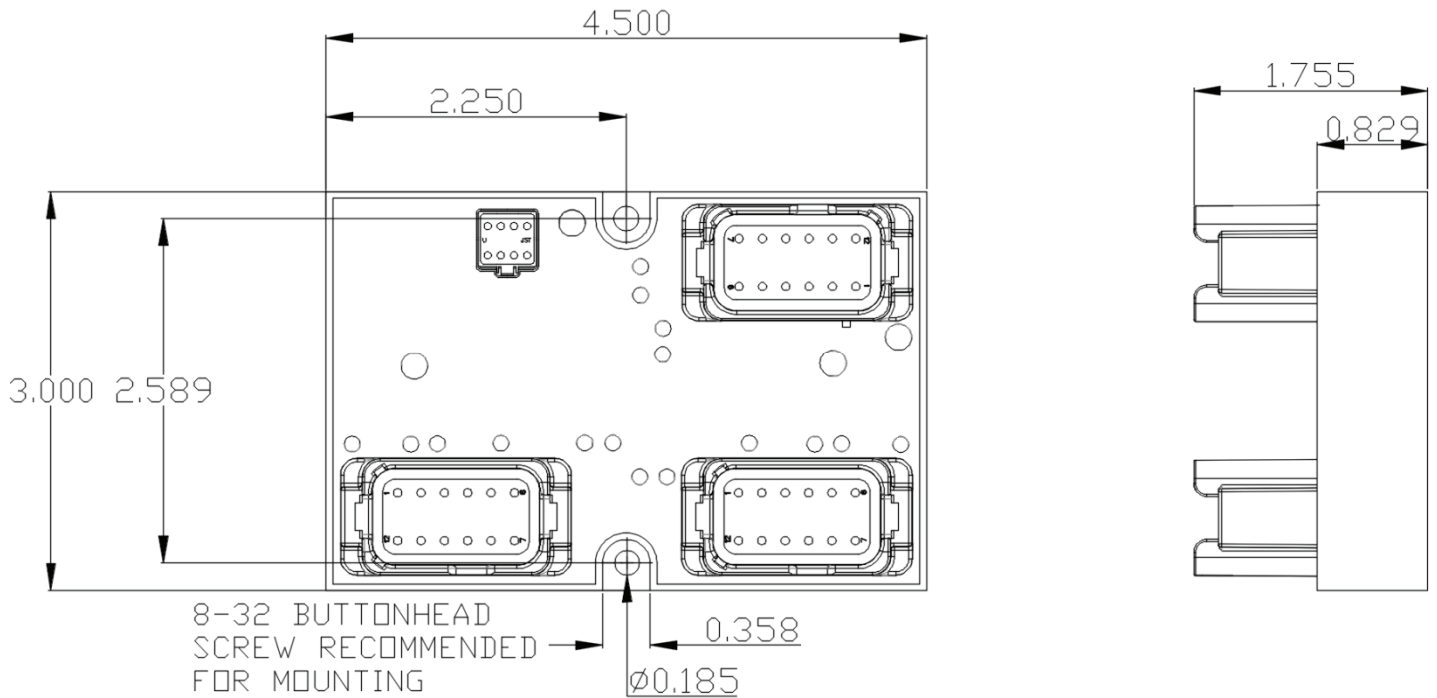

V400 Dimensions Details:

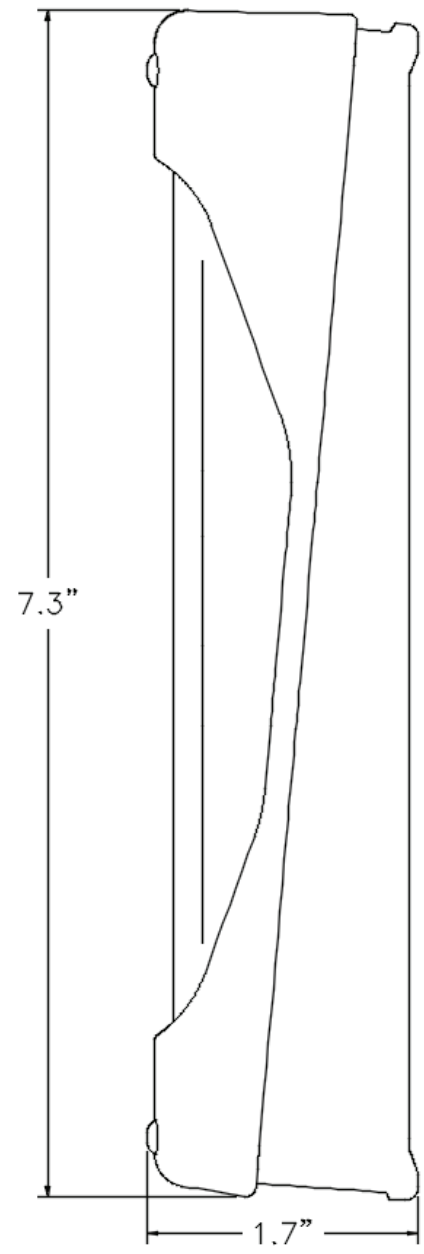
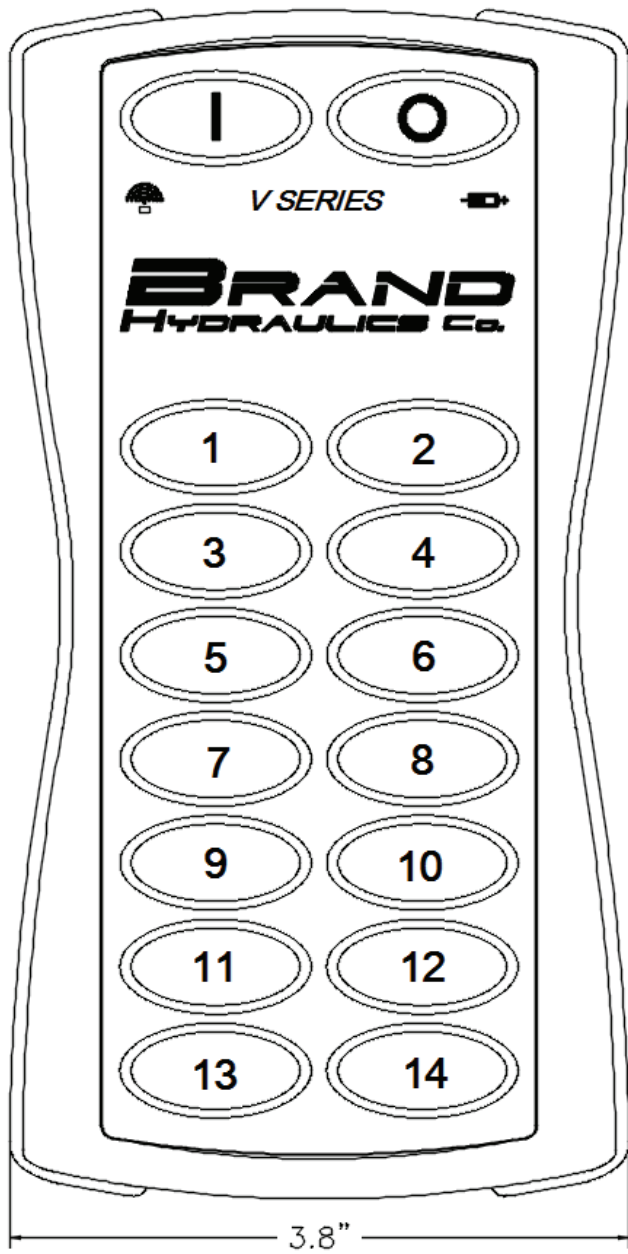

RP100 Dimensions Details:

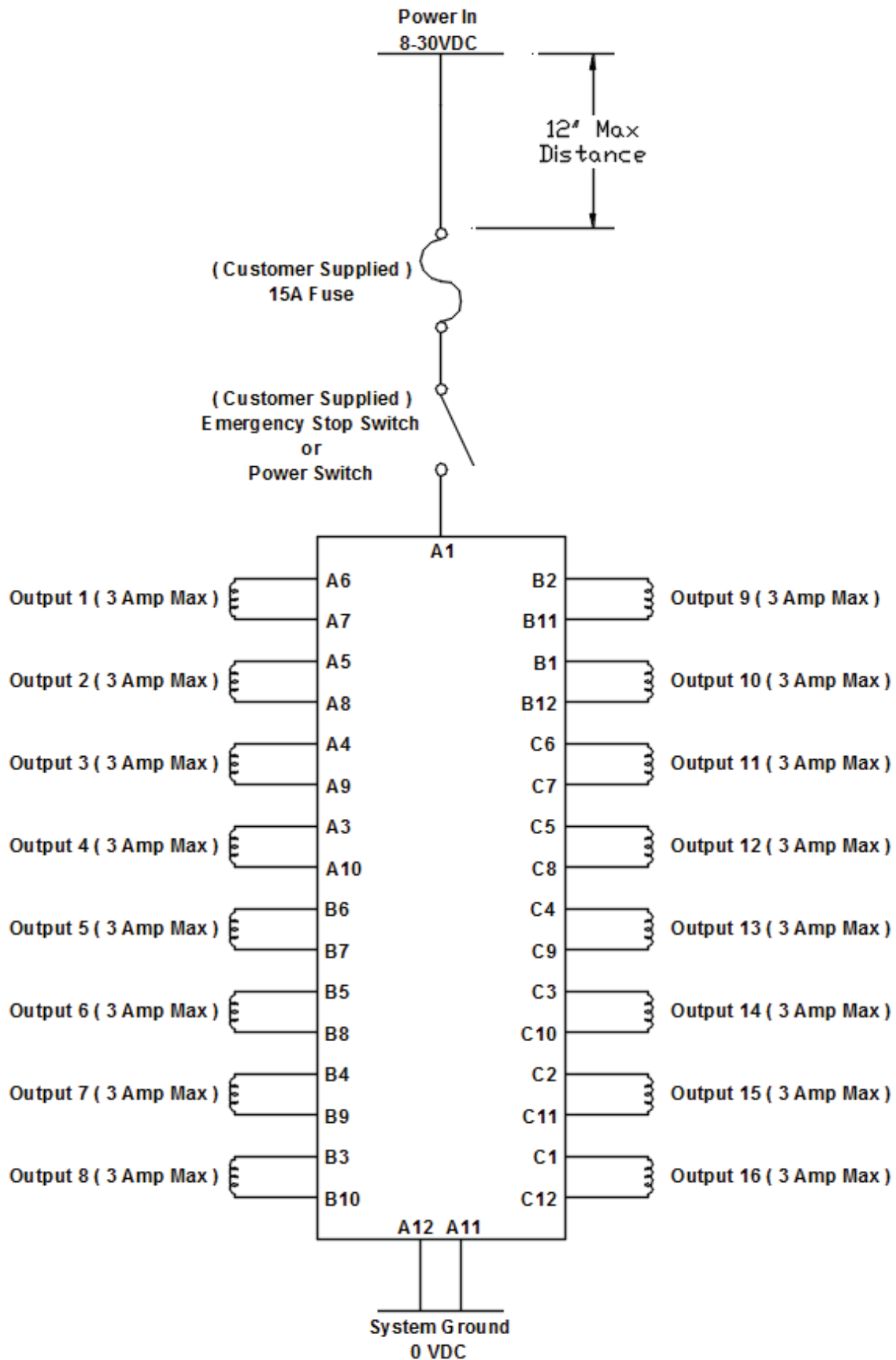

PIN "A11" – Spare Ground does not require connecting

OPERATION

Pairing:

Any transmitter can be paired with any receiver. To pair:

1. Power Cycle the receiver OFF then ON
2. On the Transmitter, Press and release the red "OFF" button
3. Press and hold the green "ON" button for approximately 10 seconds.

The pairing steps above must be completed within one minute of the receiver power cycle. The wireless activity LED on the receiver should flash orange 3 times for a successful pair. Normal operation can now resume.

Transmitter Reset:

A "hard reset" can be performed on the transmitter by holding the red "Off" button for approximately 15 seconds. The transmitter will resume normal operation after resetting.

Output Operation:

Each button on the transmitter will activate one output on the receiver. Only one operation is allowed at a time. Multiple buttons can be pressed, but only the original operation will be continued. This operation will shut down once all buttons are released. For custom applications, multiple outputs may be mapped to single buttons. Please contact Brand Hydraulics Electrical Engineering Department to discuss potential applications.

Parallel Operation:

The receiver may be used in parallel with another receiver/control to drive a common load. It is protected against current back feeding through each output.

On/Off Operation:

The "On" and "Off" button each will send a message to the receiver placing it in the corresponding state. Once in the off state, the receiver will shut down all outputs and only response to an "On" signal.

The Transmitter, once placed in the off state, will also only respond to an "On" signal.

The "Off" button/message will override any state of the receiver and transmitter. Even if another button is pressed, the "Off" button will respond appropriately.

Response Time:

The wireless network has been designed to require as little response time as possible. There should be no noticeable delay between a button press and a response from the control.

Overcurrent Protection:

A current draw over 10A will cause the control to shut down and lock out all outputs. During this time, the control will still receive messages, but will ignore them. A power cycle is required to return to normal operation.

Loss of Transmitter Protection:

During a button press, the transmitter continuously transmits the appropriate message to the receiver every 250ms. When the receiver has an output activated, it will automatically shut off the output if it does not receive a signal for 550ms. Thus, the receiver has to miss 2 messages before an automatic shut off is performed. This ensures system reliability as well as loss of transmitter protection.

Multiple Pairs in Same Area

The network design allows multiple pairs to be operated in the same area. Each transmitter and each receiver must be paired properly to ensure against interference.

Programming Connector:

The receiver uses a small, white connector for factory programming the device. The dummy plug must never be removed from the receiver to ensure ingress protection.

Custom Membranes:

Custom Membranes can be made for specific applications. Contact Brand Hydraulics for more info.

Low Battery Operation:

The "Low Battery" indicator will flash when battery capacity is less than 10%.

The transmitter will attempt to continue transmitting while battery is low. After each successful transmission, the "Transmit" LED will flash. After each button press, the battery voltage is tested and the "Low Battery" LED is lit if appropriate.

If only the "Low Battery" indicator flashes after a button press, the battery is too depleted to successfully transmit and must be replaced.

If both LED's flash, transmission was successful, but the battery needs to be replaced as soon as possible to ensure reliable operation.

TRANSMITTER BATTERY REPLACEMENT

- 1) Press the OFF button on the transmitter
- 2) Disconnect power from the receiver
- 3) Remove (4) screws from the back of the transmitter
 - a. See photo
- 4) Separate the (2) halves of the transmitter
 - a. Do NOT remove the seal skirt from the enclosure base
- 5) Gently pry and remove the old coin cell battery from the battery holder
- 6) Gently install the new battery into the holder. It should snap into the holder.
 - a. Note the direction of the battery. The + Symbol must be facing up.
- 7) Place the (2) halves of the transmitter back together.
 - a. Take your time and make sure seal fits correctly
- 8) Install the (4) screws back onto the transmitter
 - a. Do not over tighten
- 9) Turn the transmitter over and push the ON power button.
- 10) Push any function and confirm the “Transmit” LED illuminates.
- 11) Push the OFF power button.
- 12) Reconnect the power to the receiver.
- 13) The system is now ready for normal operation.



Only use 3V, CR2450 Lithium batteries



TROUBLESHOOTING

Problem	Reason	Fix
No response from receiver when transmitter button is pressed (Transmitter LED's light up after button press)	Power is not properly connected to the receiver	If the green "Power Good" LED is not lit, ensure "Power Input" and "System Ground" are properly connected. Also check that no fuses have been blown.
	Power is connected in reverse	If the amber "Reverse Polarity" LED is lit, the "Power Input" and "System Ground" connections have been reversed.
	Output is not properly connected	If the a red output LED on the receiver turns on when a button is pressed on the transmitter, the output may be improperly connected. Verify the correct output is properly connected to the load.
	Receiver is locked out due to overcurrent	The receiver will trip and lockout if 10A or more is through the board. In this scenario, the "Transmit" led will still flash everytime a message is received, but no output LED's will turn on. Check for a heavy load or short circuit, cycle power to the Receiver, and try again.
	Receiver is locked out due to a message error	The "Transmit" LED will be lit red and will not change. Cycle power to the receiver and try again.
No response from the transmitter when button is pressed.	Transmitter is in the "Off" state	Press the "On" button.
	Transmitter has a low or dead battery	If the transmitter is placed in the "On" state and the "Low Battery" LED or no LED's flash, the battery may be low or dead. Replace with a CR2450 coin cell and try again.
	Transmitter is not properly paired with receiver	The "Transmit" LED on the receiver and on the transmitter should both periodically flash while a button is held and the transmitter is in the "On" state. If only the transmitter "Transmit" LED is flashing, follow the pairing sequence found in the installation instruction.
Outputs are not properly functioning	Receiver input voltage is too low	The Receiver will connect the input voltage to the output after a button is pressed on the transmitter. If the voltage supplied is not high enough to run the connected function, it will not turn on.
	Load is too far away	If a very heavy load is placed at the end of a very long cable, the voltage can drop to a point that is too low to run the function. Shorten the cable distance or increase supply voltage.
Outputs intermittently turn off while button is held	System is out of range	Ensure that the system is within the operating range and remove as many obstacles between the receiver and transmitter as possible.
	Transmitter battery is low	Replace battery in transmitter
	Intermittent connection on the receiver	Ensure that the "Power Input", output, and appropriate ground are properly connected

WARRANTY

Warranty Policy:

Please visit our website for product warranty information.

www.brand-hyd.com/warranty

OPTIONAL PARTS

Brand Hydraulics P/N	Manufacturer P/N	Description	
E2365	N/A	Deutsch 12-contact flying lead connector assembly, A-Key, 12 – 12" leads	
E2366	N/A	Deutsch 12-contact flying lead connector assembly, B-Key, 12 – 12" leads	
E2367	N/A	Deutsch 12-contact flying lead connector assembly, C-Key, 12 – 12" leads	
E2368	DT06-12SA-P012	Deutsch 12-contact plug body, A-Key, Gray	
E2369	DT06-12SB-P012	Deutsch 12-contact plug body, B-Key, Black	
E2370	DT06-12SC-P012	Deutsch 12-contact plug body, C-Key, Green	
E2023	W12S-P012	Deutsch Wedge Lock for 12 contact plug, Green	
E1827	0462-201-16141	Deutsch Contact, Socket, Size 16, Nickel	

Brand Hydraulics P/N	Manufacturer P/N	Description	
E2024	0413-217-1605	Deutsch Sealing Plug, Locking, White	
E2401	N/A	8 – Contact plug, White	
E2363	N/A	Seal Skirt, V400, Yellow	
E2304	N/A	Enclosure Screw	
E2393	N/A	Lanyard	



Shipping: 2332 S 25th St (Zip 68105)
Mailing: P.O. Box #6069 (Zip 68106)
Omaha NE
Phone: (402) 344.4434
Fax: (402) 341.5419
www.BRAND-HYD.COM



It is the purchaser's responsibility to determine the suitability of any Brand Hydraulics product for an intended application, and to insure that it is installed in accordance with all federal, state, local, private safety, health regulations, and codes and standards. Due to the unlimited variety of machines, vehicles, and equipment on which our products can be used, it is impossible for Brand Hydraulics to offer expert advice on the suitability of a product for a specific application. We believe that it is our customer's responsibility to undertake the appropriate testing and evaluation to prevent injury to the end user.

All product, product specifications and data are subject to change without notice to improve reliability, function or design or otherwise.

