



Shipping: 2332 S 25th St
Omaha, NE 68105
Phone: (402) 344.4434
Fax: (402) 344.8091
www.BRAND-HYD.COM



LEFC FLOW CONTROL INSTALLATION & USER GUIDE

SAFETY PRECAUTIONS

- It is the purchaser's responsibility to determine the suitability of any Brand Hydraulics Co. product for an intended application, and to ensure that it is installed in accordance with all federal, state, local, private safety and health regulations, codes and standards. Due to the unlimited variety of machines, vehicles and equipment on which our products can be used, it is impossible for Brand Hydraulics Co. to offer expert advice on the suitability of a product for a specific application. It is our customer's responsibility to undertake the appropriate precautions, testing and evaluation to prevent injury to the end-user.
- Overpressure may cause sudden and unexpected failure of a component in the hydraulic system, resulting in serious personal injury or death. Always use a gauge when adjusting a relief valve.

SPECIFICATIONS:

- Max. 3000 psi cartridge input pressure.
- Nominally Rated for 3000 psi (207 bar).
- Tank Port - #4 SAE (10 psi (0.69 bar) MAX. back pressure)
- Weight 32-3/4 lbs. (14.9 kg).
- 25-Micron Filtration or Better.
- Coil 12 VDC standard.
10.4 Ohms.
14 Watts.
1.15 Amp max.
Rated 100% continuous duty cycle
- Pulse Frequency (90 to 110 Hz)
- Operating Temperature: -20° to 210°F (-30° to 100°C)

FEATURES:

- **CF port (Controlled Flow)** - Flow coming from the CF port is pressure compensated and proportional to the current received by the coil. Flow can vary from closed to wide open.
- **EX port (Excess Flow)** - Flow coming from the EX port is also pressure compensated. Note: When zero current is received by valve entire flow will exit valve via the EX port.

MOUNTING & ADJUSTMENT INSTRUCTIONS:

- **Mounting** – Valve can be mounted in any orientation. Valve must be mounted on a flat surface. Special attention should be paid to not bend or twist the casting when mounting. Doing so may cause the compensator spool to bind, causing valve to fail.
- **Manual Override Adjustment** – The flow rate from the valve can be manually adjusted. This feature can be used if power to the coil is lost for any reason.
To manually adjust valve flow: First, remove the red rubber guard from adjustment screw. Next, loosen the 5/16" jam nut. Finally, turn the override set screw clockwise with a 5/32 allen wrench to manually adjust the flow out of the CF port.
- **Cartridge Tank Port** – The cartridge valve body has a tank port (#4 SAE fitting) machined into it. In order for the internal cartridge valve to operate correctly, it must be plumbed back to tank with a **MAXIMUM of 10 psi** back pressure allowed. We recommend plumbing the tank port directly back to tank avoiding any filter.



Shipping: 2332 S 25th St
 Omaha, NE 68105
 Phone: (402) 344.4434
 Fax: (402) 344.8091
 www.BRAND-HYD.COM



FREQUENTLY ASKED QUESTIONS:

Q: Can the CF port be blocked or plugged?

A: No. If the CF port is blocked or plugged for any reason the compensation spool will attempt to compensate for increasing pressure, and shift thus blocking the EX port as well, and rendering valve inoperable. **DO NOT BLOCK CF PORT.**

Q: Can the EX port be blocked or plugged?

A: The EX port can be blocked or plugged, but doing so requires a pressure compensated or load sense pump.

Q: Can flow be sent in reverse through valve.

A: It is not recommended to send flow in reverse, as it will cause valve to become inoperable.

Q: How many amps are required to shift orifice spool to full flow?

A: 0.85 amp is required to fully shift orifice spool. 250 mA is generally the amperage needed to see flow begin from the CF port.

FREQUENTLY ASKED QUESTIONS Cont'd:

Q: Can I add a relief to my LEFC valve?

A: The LEFC is unable to have a relief installed.

Q: What kits are available for this valve?

A: There is a replacement seal kit available for this valve. (Part #: LEFC-K)

DIMENSIONAL DATA

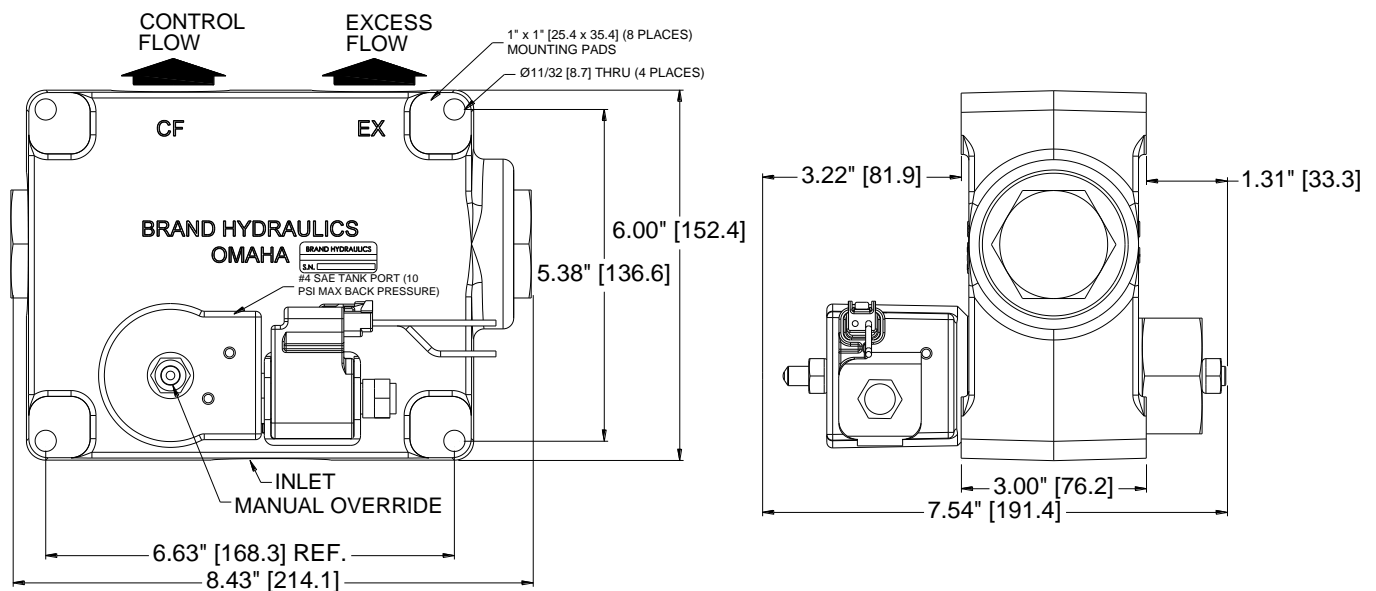



Shipping: 2332 S 25th St
 Omaha, NE 68105
 Phone: (402) 344.4434
 Fax: (402) 344.8091
 www.BRAND-HYD.COM



WIRING & HYDRAULIC SCHEMATIC (2 OR 3 PORT):

CF-CONTROLLED FLOW
 PRIORITY PORT, PRESSURE
 COMPENSATED

EX-EXCESS FLOW IS PRESSURE
 COMPENSATED. THE FLOW CAN BE
 USED TO DO WORK OR RAN BACK
 TO TANK.

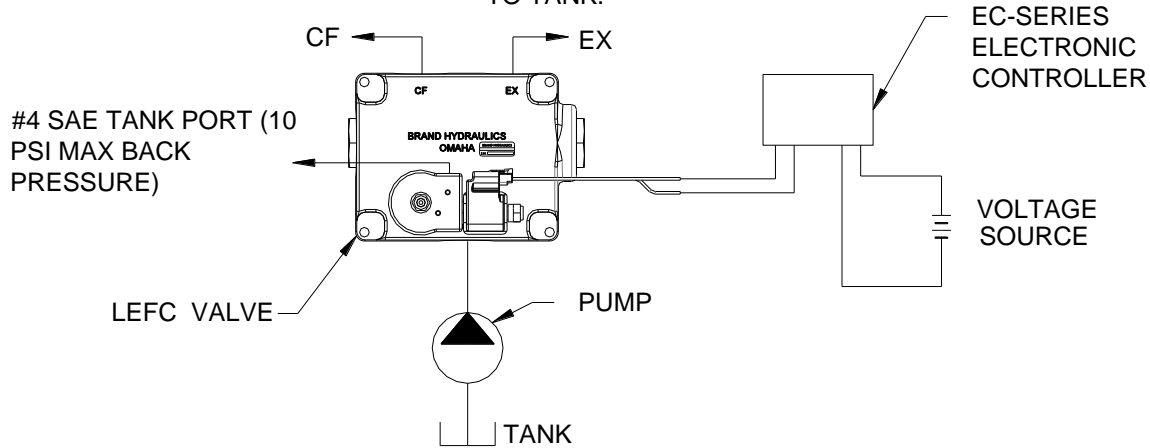

FLOW & SOLENOID CURRENT INFORMATION:

Controlled Flow vs. Solenoid Current

Oil Temp=110 deg. F w/ 140-147 SUS Oil

